

**SUPPLEMENTARY DOCUMENTATION  
NATIONAL ASSET MANAGEMENT AGENCY  
16<sup>TH</sup> SEPTEMBER 2009**

**INFORMATION BOOKLET**

<b>SECTION</b>	<b>PAGE</b>
1. NAMA HIGH LEVEL STATISTICS	2
2. PROPERTY YIELDS	10
3. DRAFT NAMA VALUATION REGULATIONS	16
4. CREDIT PACKAGE UPDATE	25
5. COVERED INSTITUTIONS – AN OVERVIEW	33
ALLIED IRISH BANK (AIB)	
BANK OF IRELAND (BOI)	
ANGLO IRISH BANK	
IRISH LIFE & PERMANENT (IL&P)	
IRISH NATIONWIDE BUILDING SOCIETY (INBS)	
EDUCATIONAL BUILDING SOCIETY (EBS)	



## SECTION 1

# NAMA HIGH LEVEL STATISTICS





## Geographic breakdown of potential portfolio for transfer to NAMA (guaranteed institutions only)

Geographic breakdown	
Ireland	66%
NI	6%
UK	21%
USA	3%
Europe	4%
<b>Total</b>	<b>100%</b>

Geographic breakdown of potential portfolio to transfer to NAMA

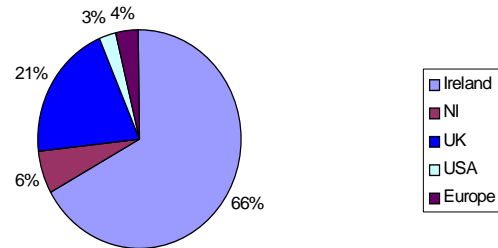

Total L&D	
Ireland	67%
NI	7%
UK	21%
USA	3%
Europe	2%
<b>Total</b>	<b>100%</b>

Geographic breakdown of the potential L&D portfolio for transfer to NAMA

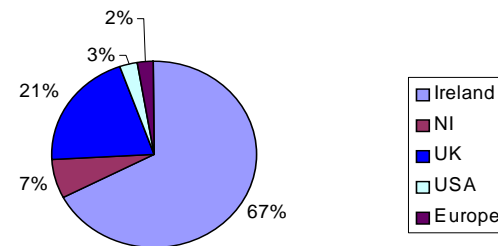

Total Associated loans	
Ireland	67%
NI	5%
UK	20%
USA	2%
Europe	6%
<b>Total</b>	<b>100%</b>

Geographic breakdown of potential total associated loans for transfer to NAMA

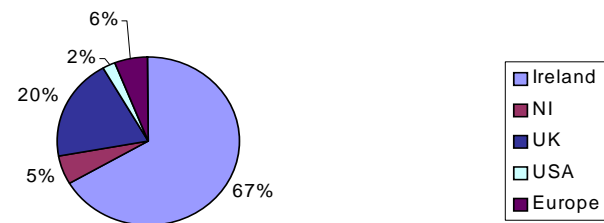

**Sectoral breakdown of potential portfolio to transfer to NAMA (guaranteed institutions only)**

**Sectoral Breakdown of potential portfolio to transfer to NAMA**

Loan book category	
Land	36%
Development	28%
Sub Total L&D	64%
Associated loans	36%
Total	100%

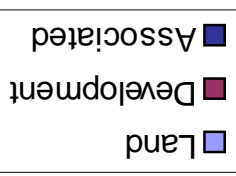
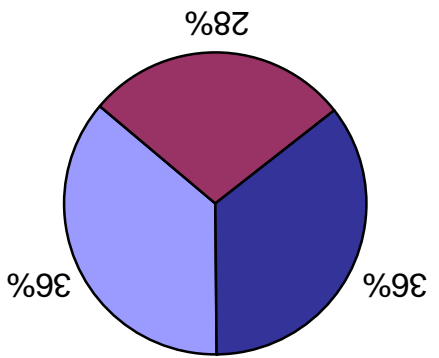

## **NAMA – Top down illustrative explanation of NAMA estimates of aggregate loan purchase price\***

An illustrative explanation of the basis for the NAMA estimate of aggregate loan asset purchase prices is as follows:

- The current book value of the total loans that NAMA has identified for potential acquisition is approximately €77 billion.
- Of these loans approximately €10 billion is rolled up interest. When NAMA is determining the market value of the assets it will first exclude the rolled up interest –giving a net balance of approximately €67 billion.
- An asset value at origination of approximately €87 billion is assumed having regard to institution estimates of average LTV at origination and NAMA estimates of interest roll up.
- It is necessary for this exercise to take a view on the decline on the underlying property collateral since the loan was originated e.g., Irish property prices have fallen by an average of 50%. Various factors particularly geographic location and future cash flows including rental income will influence this valuation. NAMA estimates an approximate 47% average decline on an aggregate portfolio basis.
- This provides an estimate of the current market value of the underlying security.

*\* This is not how the valuation methodology will apply but for illustrative purposes only*

Applying these factors NAMA estimates the current market value of the underlying assets as follows:

Potential		£bn
	Potential total book value for transfer to NAMA	77
	Interest Roll up Estimate	10
	Balance excluding roll up	67
	Approximate average LTV	77%
	Assets value at origination	87
	potential decline in property prices approximate estimate	47%
	<b>Estimated current market value of underlying asset</b>	<b>46</b>

If NAMA actually pay €54 billion as the acquisition value of the loans it would represent a 30% haircut on the book value of the €77 billion loans.

	Potential	total
		€bn
Potential total book value of loans		77
30% haircut on loans		30%
<b>Price NAMA could pay for loans</b>		<b>54</b>

NAMA estimates, based on the application of the statutory adjustment factors, that the long term economic value will present approximately 17% of an uplift on the current market value of the loans identified for transfer. On the basis of current analysis NAMA estimate that a 30% discount on the book value of loans represents a reasonable estimate of the likely acquisition value of the assets to be transferred. Finalisation of such numbers will not take place until full completion of bottom up valuation is completed by NAMA. In the realisation of NAMA acquired loan portfolio it is estimated asset prices would have to recover by 11.5% to avoid any loss to the taxpayer and taking the subordinated debt into account.

**Scenario of potential impact of NAMA on Irish Debt ratios – Pro Forma adjustment not projections, figures as at the Supplementary Budget 2009**

	2009	2010	2011	2012	2013
--	------	------	------	------	------

<b>SUPPLEMENTARY BUDGET APRIL 2009</b>	59%	73%	78%	79%	77%
GG Debt/GDP	47%	61%	69%	72%	73%
Debt/GDP (net of cash held by the NTMA)					

<b>SUPPLEMENTARY BUDGET APRIL 2009</b>	0	54	54	54	48
(adjusted for NAMA)					
NAMA Debt (€bn)					

Debt (NAMA consolidated)/GDP	59%	105%	109%	108%	102%
Debt (NAMA consolidated)/GDP (net of cash held by the NTMA)	47%	93%	99%	101%	97%

**This table is for illustrative purposes only and is NOT a General Government Debt forecast**

- Discussions are ongoing with the CSO but early indications suggest that the instruments issued to purchase eligible loan assets from participating institutions will be treated as off balance sheet instruments.

- The figures above are based on Supplementary Budget April 2009 figures.

- General Government Debt is a gross measure and does not take account of any cash balances held by the State or assets held by the National Pension Reserve Fund (NPRF) or potential assets to be held by NAMA.



SECTION 2  
PROPERTY YIELD



## Property Yields

A property yield is derived by expressing a year's rental income as a percentage of the property cost. There is an inverse relationship between yields and property prices; as property prices rise, yields fall.

**Table 1**

### **Yields in certain European cities**

The prime yields broadly represent the market's evaluation of the attractiveness of investment in property. It is clear from the table that follows the majority of European cities current prime yields are higher than their long term 20 year average, particularly Dublin where the Prime Yield is at 7.25% in comparison to a 5.56% long term average.

As yields move towards their long term average this would indicate an increase in property prices given the inverse relationship between yields and the underlying property prices.

**Table 2**

### **Relationship between Property Yields, EURIBOR Rates & 5 Year Euro Swap Rates**

The EURIBOR rates and the 5 year Euro swap rates are reference interest rates that are regularly used in financial markets. As is clear from the chart there is a large gap between the property yield in Ireland and the various interest rates, this is called the "yield gap". This gap is at its widest point since 1997.

Two factors would bring a decrease in the gap:

- An increase in interest rates
- An increase in property prices, resulting in a decrease in yields

### **Table 3**

#### **Irish Prime Yields 1983 – August 2009**

The table deals with Irish yields only and shows the yields for offices, retail and industrial (i.e. warehouses). It is clear from the table that the yields for office and retail in particular are at their highest level over the period examined since 1983.

Yields in certain European cities

City	Prime Yield	Long term Average (20 years)
Berlin	5.50	5.17
Dusseldorf	5.40	5.08
Frankfurt	5.40	4.88
Hamburg	5.00	4.95
Helsinki	6.00	5.93
London City	7.00	5.68
London West	6.00	4.97
End	6.00	4.97
Paris	5.50	5.15
Rome	5.25	5.41
Dublin	7.25	5.56

Source: JLL

# Relationship between Property Yields, EURIBOR Rates & 5 Year Euro Swap Rates

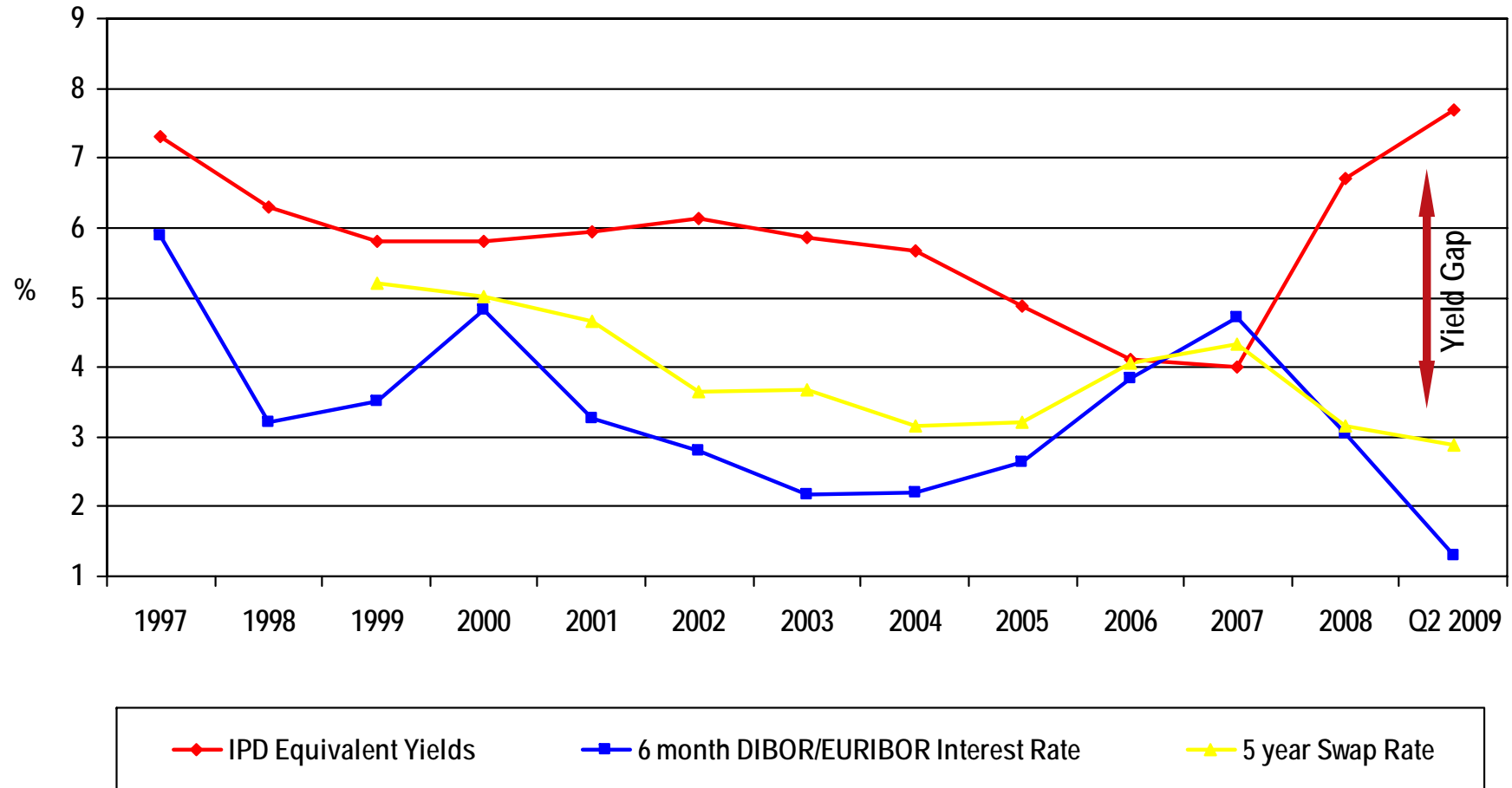

Source: JLL, IPD, Bloomberg, September 2009

# Prime Yields 1983 - Aug 2009 (Mid Point)

Source: JLL

	Office	Retail	Industrial
5 year average	5.36	4.03	6.39
10 year average	5.38	3.87	6.60
Series average (1983-Q2 2009)	5.93	4.85	8.18

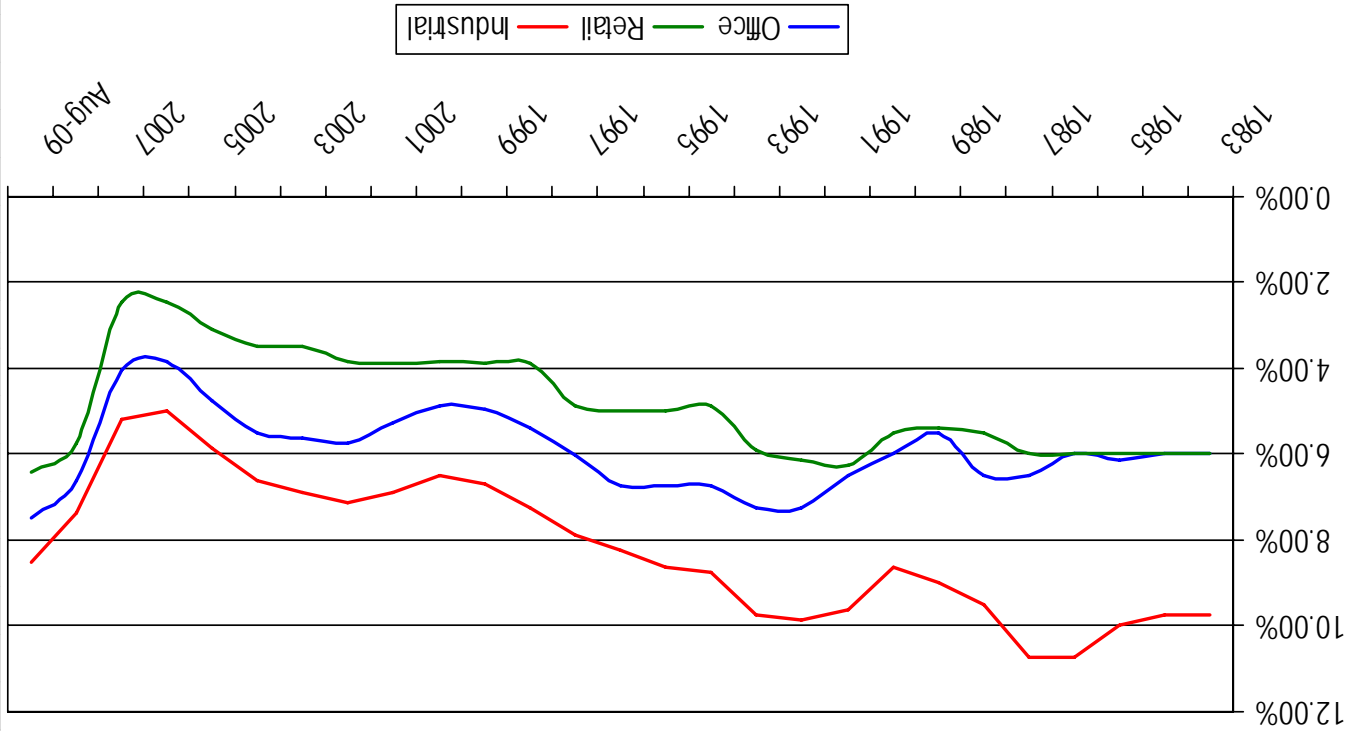

Year	Offices	Retail	Indus
1983	6.0	6.0	9.75
1984	6.0	6.0	9.75
1985	6.13	6.0	10.00
1986	6.0	6.0	10.75
1987	6.5	6.0	10.75
1988	6.5	5.5	9.5
1989	5.5	5.38	9.0
1990	6.0	5.5	8.63
1991	6.5	6.25	9.63
1992	7.25	6.13	9.88
1993	7.25	5.9	9.75
1994	6.75	4.88	8.75
1995	6.75	5.0	8.63
1996	6.75	5.0	8.25
1997	6.03	4.88	7.88
1998	5.38	3.88	7.25
1999	4.95	3.88	6.70
2000	4.88	3.85	6.50
2001	5.25	3.88	6.88
2002	5.75	3.85	7.13
2003	5.63	3.5	6.88
2004	5.5	3.5	6.63
2005	4.75	3.08	5.88
2006	3.85	2.45	5.00
2007	4.05	2.45	5.18
2008	6.63	5.75	7.38
Aug 09	7.50	6.40	8.50



## SECTION 3

# DRAFT NAMA VALUATION REGULATIONS



# DRAFT FOR CONSULTATION PURPOSES

Draft of

## REGULATIONS

entitled

**National Asset Management Agency (Determination of Long-Term Economic  
Value of Property and Bank Assets) Regulations 2009**

---

To be made by the  
Minister for Finance

I, \_\_\_\_\_ Minister for Finance, in exercise of the powers conferred on me by section 77 of the National Asset Management Agency Act 2009 (No. \*\*\* of 2009), having had regard to the laws of the European Communities governing State aid and the other matters referred to in paragraphs (a) and (b) of section 77(2) of that Act, hereby make the following Regulations:

**Citation.**

1. — These Regulations may be cited as the National Asset Management Agency (Determination of Long-Term Economic Value of Property and Bank Assets) Regulations 2009.

**Definitions.**

2.—In these Regulations –

“class”, in relation to land, means any class of land that is differentiated by reference to the type of land, the purpose for which the land is used, the location of the land, or any other characteristic or combination of characteristics;

“land” means land which is the subject of the security for a credit facility that is a bank asset;

“NAMA discount rate” means the Irish 10 year Government Bond rate at the establishment date plus \* per cent;

“parcel of land” means an individual plot of land;

“relevant period” means the period that began on 1 January 1985 and ended on 31 December 2005.

**Adjustment factor- property other than land.**

3. — No adjustment factor shall be applied to the market value of any property other than land, and the long term economic value of such property shall for all purposes be its market value.

**Adjustment factor to be applied - land.**

**4.** — (1) In calculating the long term economic value of a parcel of land, NAMA shall be entitled to apply different adjustment factors to different parcels or classes of land, or the same factor in different proportions to different parcels or classes of land, as it considers appropriate in the circumstances.

(2) Any adjustment factor or proportion of an adjustment factor so applied shall be applied on a straight line basis over 7 years.

(3) Any adjustment factor referred to in paragraph (1) shall be derived in accordance with Regulation 5 or 6 as the case may be.

**Adjustment factor - land located in State.**

**5.** — (1) An adjustment factor for a parcel of land located in the State shall be derived by NAMA in accordance with these Regulations in such manner as it thinks fit, by reference to such of the following as it considers relevant:

- (a) the difference between -
  - (i) the prices or yields of land located in the State on the valuation date, and
  - (ii) the prices or yields of land located in the State over the relevant period as determined by reference to such of the bulletins and indices specified in Schedule 1 and such other similar relevant bulletins and indices as NAMA may consider appropriate in the circumstances;
- (b) the correlation, in the relevant period -
  - (i) between land prices and demographic variables relating to the State,
  - (ii) between land prices and interest rates in the State, and
  - (iii) between land prices and the State's gross domestic product;

(c) projections of land prices, demographic variables, interest rates and the State's gross domestic product in respect of any period or periods beginning on or after the valuation date and ending on a day which is no later than 5 years after the valuation date, which are made by the bodies mentioned in paragraph (2) and available to NAMA not later than 30 days after the valuation date; and

(d) data and analyses which are provided to NAMA not later than 30 days after the valuation date by any or all of the following:

(i) the Minister for the Environment, Heritage and Local Government on the extent to which existing land zoning and planning permissions granted and in force meet or exceed projected growth requirements in the State;

(ii) the Minister for Transport, or the Dublin Transportation Office or an appropriate national transportation authority, on existing and future transport planning and the associated supply and demand projections for land use; and

(iii) the Minister for Communications, Energy and Natural Resources in relation to the potential rise in energy and other costs due to the long-term decline in non-renewable resources.

(2) The relevant correlation for the purposes of paragraph (1)(b) is to be determined by NAMA having regard, as NAMA considers appropriate, to such of the data and analyses as are available to NAMA not later than 30 days after the valuation date and as are prepared by any or all of the following:

(a) Central Statistics Office;

(b) Economic and Social Research Institute; and

(c) Central Bank and Financial Services Authority of Ireland.

**Adjustment factor - land located in state other than State.**

6. — (1) An adjustment factor for a parcel of land located in a state other than the State shall be derived by NAMA in accordance with these Regulations in such manner as it thinks fit, by reference to such of the following as it considers relevant:

- (a) the difference between -
  - (i) the prices or yields of land located in the state in which the parcel is located on the valuation date, and
  - (ii) the prices or yields of land located in that state over the relevant period as determined by reference to such of the published bulletins and indices specified in Schedule 2, and such other similar relevant bulletins and indices, as NAMA may consider appropriate in the circumstances;
- (b) the correlation, in the relevant period -
  - (i) between land prices and demographic variables relating to the state in which the parcel is located,
  - (ii) between land prices and interest rates in that state, and
  - (iii) between land prices and that state's gross domestic product;and
- (c) data and analyses which are provided to NAMA not later than 30 days after the valuation date by the Minister for Communications, Energy and Natural Resources in relation to the potential rise in energy and other costs due to the long-term decline in non-renewable resources.

(2) The relevant correlation for the purposes of paragraph (1)(b) is to be determined by NAMA having regard, as NAMA considers appropriate, to such of the data and analyses as are published not later than 30 days after the valuation date by any official national bodies equivalent or comparable to those specified in Regulation 5(2) of the

state in which the land is located, and any other equivalent bodies, as NAMA may consider appropriate in the circumstances.

**Overall limitations.**

**7. —** Notwithstanding any other provision of these Regulations-

(a) the long term economic value of a particular parcel of land shall not exceed its market value by more than one-quarter,

(b) the aggregate of the long term economic value of all land valued in connection with the acquired portfolio of each participating institution shall not exceed the aggregate of the market values of that land by more than one-fifth, and

(c) NAMA may determine in respect of a particular parcel of land that no adjustment factor is appropriate, having regard to the special circumstances relating to the parcel.

**Variables for determination of long term economic value of bank assets.**

**8. —** In calculating the long term economic value of a bank asset, NAMA shall take into account the following variables:

(a) an extension of the maturity date of the bank asset for one year, to take account of a reasonable enforcement period; and

(b) the cash flows of the bank asset over a period of 7 years or the lesser period which ends on the maturity date of the bank asset specified in the credit facility concerned, using the NAMA discount rate.

## SCHEDULE 1

- SCS / IPD Irish Quarterly Property Index except for the years 2005 to 2008
- Department of the Environment Housing Statistics Bulletin, except for the years 2005 to 2008
- JLL Irish Property Index except for the years 2005 to 2008

## SCHEDULE 2

<b>Location of Property</b>	<b>Bulletins and Indices</b>
Great Britain or Northern Ireland:	<ul style="list-style-type: none"> <li>• Nationwide House Price Indices including Northern Ireland</li> <li>• Halifax House Price Indices including Northern Ireland</li> <li>• IPD Monthly Index UK All Sectors</li> <li>• Land Registry House Price Index</li> </ul>
United States of America	<ul style="list-style-type: none"> <li>• Case - Shiller Home Price Index</li> <li>• NCREIF Property Index</li> <li>• Moodys/REAL Commercial Property Price Index (CPPI)</li> <li>• FTSE NAREIT US Real Estate Index Historical Values and Returns.</li> </ul>
Europe, except for the State, Great Britain and Northern Ireland	<ul style="list-style-type: none"> <li>• EPRA Index</li> <li>• IPD Pan European Index</li> <li>• Any equivalent document published in the relevant place or regarding that place</li> </ul>
Any other place	Any equivalent document published in the relevant place or regarding that place

GIVEN under my Official Seal,

\_\_\_\_\_ 2009.

\_\_\_\_\_

Minister for Finance

**SECTION 4**  
**CREDIT PACKAGE UPDATE**



## **Credit Package**

As part of the Recapitalisation of AIB and Bank of Ireland, a package of measures, to be put in place by the banks, was agreed. Banks report quarterly on their compliance with the agreement and their reports are examined by the Financial Regulator.

A detailed note on each bank based on the quarterly reports is shown on the following pages.

### **SME Lending**

The banks obligation is to make credit available, rather than to reach a specified level of lending. Both banks have reported that they have made funding available to meet this requirement, although actual lending levels remain well down on last year. As was made clear by the Mazars Review, demand for credit from SMEs is substantially down on previous levels.

The figures show a significant flow of SME lending up to June. (BOI report drawdown of €1.4bn, while AIB report €1.3bn “additional credit sanctions” and €859m. drawdown in the first half of this year). It is clear that credit drawdown/approvals are substantially down on the same period last year, but the amounts are still substantial and represent a significant level of activity.

Both banks report substantial numbers of new business accounts opened – over 16,000 in the first half of the year - although again the figures are less than last year.

Overall, although particular sectors are experiencing considerable business difficulties, which affect access to credit, as was made clear by the Mazars Review, the flow of funds to SMEs remains substantial.

### **Mortgage lending**

Overall Mortgage lending is substantially down – both applications and drawdown are well behind last years levels. There is some anecdotal evidence, supported by the bank figures, that loan approvals are high relative to drawdown.

The Government was particularly concerned about the position of First Time Buyers (FTB) and increased capacity for FTB lending was specified in the Recapitalisation agreement. Banks have confirmed that funds are available. FTB applications have been running strongly all this year, the monthly amounts drawn down have risen sharply and, in the case of AIB, were ahead of last years figure in recent months.

### **Other Aspects**

The Recapitalisation agreements contain a number of other requirements, designed to ensure the continued flow of credit to sound businesses, support for environmental improvements, an assurance of better treatment for business and mortgage customers through the statutory Codes of Conduct, and support for better financial education and the introduction of Basic Bank Accounts.

## Allied Irish Bank

### Recapitalisation

AIB advises that it has taken the following action to meet the commitments made in respect of the **Credit Package**:

### SME Lending Capacity

AIB introduced a support package for SMEs in December 2008 incorporating the restructuring of loan facilities over longer terms, interest only options for up to 2 years, maintaining working capital support and a Start-Up Fund to support new investment. In March 2009 AIB introduced a €100 million Loan Fund supported by the European Investment Bank, targeted at investment projects that support business expansion.

AIB committed to providing an additional 10% capacity for lending to SMEs in 2009. The total amount of lending to SMEs at the end of 2008 was €3.8 billion, and AIB has sanctioned an additional €1.3 billion in credit facilities in the 6 months to June 2009. The total amount of lending outstanding at the end of June 2009 was €3.5 billion. The change from year end 2008 to end June 2009 takes account of additional drawdowns, interest charged and repayments by customers, and does not incorporate provisions for impaired loans. At the end of June 2009, €1.2 billion (or 46%) of sanctioned overdraft limits had not yet been drawn down by customers.

Lending to the SME sector during the first two quarters of 2009:

	Number of additional limits sanctioned	Additional sanctions value	Drawdowns
Quarter 1 2009	16,059	€746m	€490m
Quarter 2 2009	12,890	€568m	€369m
<b>Total Half-Year to June 2009</b>	<b>28,949</b>	<b>€1,314m</b>	<b>€859m</b>

In the 6 months ending June 2009, AIB opened 4,100 new business current accounts. This compares with 5,000 accounts for the same period in 2008. These figures exclude additional accounts opened by existing business customers.

### Independent Review of Credit Availability

AIB has contributed to funding of the independent review of credit availability. AIB has fully engaged with the process leading to publication of the Mazars report on July 10<sup>th</sup> 2009.

### Venture Capital Funding

AIB has agreed to provide an additional €15 million funding to Enterprise Ireland's Seed and Venture Capital programme. AIB had previously provided funding of €15 million to this programme, making a total investment by AIB of €30 million.

### **Code of Conduct for Business Lending**

AIB participated with the Financial Regulator in the development of the Code of Conduct for Business Lending and is on schedule to complete implementation of the Code in September 2009 as required.

### **Credit for Suppliers to Major Projects**

A process has been put in place with Enterprise Ireland to address situations where there are issues regarding the flow of credit to viable projects.

### **Environmental Fund**

AIB launched a €100 million Environmental Fund in June 2009 to cater for personal and business customers who wish to undertake projects that have a positive impact on the environment.

### **First Time Buyer Mortgages**

AIB committed to providing an additional 30% capacity for mortgage lending to First Time Buyers. The number of First Time Buyer sanctions for the half year to June 2009 showed an increase of 31% on the same period in 2008.

First Time Buyer Mortgage Sanctions:

	Jan-June 2008	Jan-2009	June	% change
<b>Number</b>	<b>1,641</b>	<b>2,144</b>		<b>31%</b>
<b>Value</b>	<b>€117m</b>	<b>€181m</b>		<b>15%</b>

First Time Buyer Drawdowns

	Jan-June 2008	Jan-2009	June	% change
<b>Number</b>	<b>1,117</b>	<b>1,566</b>		<b>40%</b>
<b>Value</b>	<b>€268m</b>	<b>€342m</b>		<b>28%</b>

### **Mortgage Arrears**

AIB has fully implemented the requirements of the Code of Conduct on Mortgage Arrears which was published by the Financial Regulator in February 2009.

### **Prompt Payment**

AIB has adopted a policy of expediting the settlement of invoices with suppliers of goods and services by making payment without taking credit terms.

### **Financial Inclusion**

In addition to the commitments in respect of the **Credit Package**, AIB has progressed the implementation of the broader commitments made as part of the Recapitalisation agreement in respect of financial inclusion:

AIB has stated its support for the **Basic Bank Account** proposal. It has been agreed that this proposal will be progressed under the auspices of the National Payments Implementation Plan (NPIP).

A study of **Financial Capability** in Ireland was published by the Financial Regulator in March 2009, and the Report of the Steering Group on **Financial Education** was published in July 2009. AIB has committed to working with other stakeholders to address the findings and recommendations from these reports, including provision by AIB of a fund to support personal financial education initiatives.

As required, AIB submitted proposals to the Financial Regulator in January 2009 to improve the **transparency of communications in respect of financial products**, and a number of the proposals have since been implemented by AIB.

## Bank of Ireland

### Recapitalisation

Bank of Ireland has reported on its actions to meet the commitments made in respect of the **Credit Package** as follows:

### SME Lending Capacity

As part of the recapitalisation agreement, Bank of Ireland committed to providing an additional 10% capacity for lending to SMEs in 2009.

Bank of Ireland introduced a business support fund of €250 m for SMEs in December 2008.

In March 2009 Bank of Ireland introduced a €100 million Loan Fund supported by the European Investment Bank, targeted at investment projects that support business expansion.

The total amount of **new** lending to SMEs in 2008 was €5 billion including construction and property lending to SMEs. The total for new lending excluding construction and property was €2.7 billion in 2008.

Lending to the SME sector during the first two quarters of 2009 was as follows:

	Lending drawdown value Core SME	Lending drawdown value Non Core SME	Lending drawdown value Total
Quarter 1 2009	€97.3m	€86.7m	€84m
Quarter 2 2009	€16m	€43.4m	€59.4m
<b>Total Half-Year to June 2009</b>	<b>€1,013.3m</b>	<b>€30.1m</b>	<b>€1,543.4m</b>

Core SMEs include all “trading” businesses and exclude property and related activities. Non Core SMEs include property, speculation and related activities.

The rise in Quarter 2 reflects a continuing upswing from a low point in the early months of the year.

The number of business current accounts opened in the first half of 2009 was 12,073, a reduction of 21.1% on the 15,301 accounts opened in the first half of 2008.

There are no lending capacity constraints affecting lending to SMEs.

### Independent Review of Credit Availability

Bank of Ireland has contributed to funding of the independent review of credit availability and fully engaged with the process leading to publication of the Mazars report on July 10<sup>th</sup> 2009.

### **Venture Capital Funding**

Bank of Ireland has agreed to provide an additional €17 million funding to Enterprise Ireland's Seed and Venture Capital programme. This figure exceeds the €15 million it committed to under the recapitalisation agreement.

### **Code of Conduct for Business Lending**

Bank of Ireland participated with the Financial Regulator in the development of the Code of Conduct for Business Lending. The Bank is fully committed to implementing the new code of conduct within the agreed time span.

### **Credit Supply Clearing Group**

Bank of Ireland has participated in the both central and regional meetings of the Credit Supply Clearing Group. It has dealt with issues arising from the Group.

### **Environmental Funds**

Bank of Ireland has established two funds, a €100 million Environmental Fund for environmental project finance and a €100m Green Business Loan for general SMEs.

### **First Time Buyer Mortgages**

Bank of Ireland committed to providing an additional 30% capacity for mortgage lending to First Time Buyers. A First Time Buyers fund of €1 billion was launched in February 2009. The number of First Time Buyer drawdowns in the first half of 2009 was approximately 1250 totalling over €250million. These figures are lower than those for the first half of 2008 when there were 1915 First time buyer drawdowns totalling €477 million.

<b>Mortgage Performance - 2009</b>	<b>Jan-09</b>	<b>Feb-09</b>	<b>Mar-09</b>	<b>Apr-09</b>	<b>May-09</b>	<b>Jun-09</b>
<b>FTB Drawdowns (number)</b>	157	159	151	208	274	308
<b>FTB Drawdowns (value €m)</b>	36	36	34	41	51	60
<b>FTB Drawdowns % (number)</b>	20%	19%	21%	22%	27%	31%
<b>FTB Drawdowns % (value)</b>	25%	24%	27%	25%	32%	37%

The number of First Time Buyer drawdowns and the amounts involved have increased in 2009 and First Time buyers took up a higher percentage of overall mortgage lending. The number of First Time Buyer approvals for September 2008 was 292, with a value of €69m, while in June 2009 there were 492 approvals, with a value of €107m.

### **Mortgage Arrears**

Bank of Ireland has confirmed that it is acting in accordance with the Code of Conduct on Mortgage Arrears which was published by the Financial Regulator in February 2009.

### **Prompt Payment**

Bank of Ireland has committed to remitting late payment interest to vendors whose invoices are not paid on time.

## **Financial Inclusion**

In addition to the commitments in respect of the **Credit Package**, Bank of Ireland has progressed the implementation of the broader commitments made as part of the Recapitalisation agreement in respect of financial inclusion:

Bank of Ireland is fully committed to the introduction of a basic bank account and has participated in meetings on its introduction.

The Bank is an active participant in the IBF working group tasked with reporting on the Corporate Social Responsibility section of the Government Guarantee Scheme. Financial Education is included as one of the headings of this report.



## SECTION 5

### COVERED INSTITUTIONS – AN OVERVIEW

The information in this document has been confirmed by the institution to which it relates for this publication. It is published for illustrative purposes only and should not be relied upon for any other purpose. The Minister for Finance, the Government of Ireland or their advisers have not independently verified the information and take no responsibility for its accuracy or completeness.



## **AIB INFORMATION PACK**

The information in this document has been confirmed by the institution to which it relates for this publication.

It is published for illustrative purposes only and should not be relied upon for any other purpose.

The Minister for Finance, the Government of Ireland or their advisers have not independently verified the information and take no responsibility for its accuracy or

## Profit and Loss Account

€m	6m to 30 June 08	6m to 30 June 09	12m to 31 Dec 08
Net interest income	1,865	1,691	3,867
Non interest income	580	1,090	1,201
<b>Total operating income</b>	<b>2,445</b>	<b>2,781</b>	<b>5,068</b>
Administrative expenses	(1,130)	(968)	(2,187)
Other expenses	(74)	(75)	(170)
<b>Total operating expenses</b>	<b>(1,204)</b>	<b>(1,043)</b>	<b>(2,357)</b>
<b>Operating profit before provision</b>	<b>1,241</b>	<b>1,738</b>	<b>2,711</b>
Provision for impairments	(137)	(2,373)	(1,822)
Other provisions	(1)	(23)	(27)
<b>Operating profit</b>	<b>1,103</b>	<b>(658)</b>	<b>862</b>
Income from associates	57	(227)	42
Other items	119	13	130
<b>Profit before tax</b>	<b>1,279</b>	<b>(872)</b>	<b>1,034</b>
Tax	(194)	86	(144)
<b>Profit after tax</b>	<b>1,085</b>	<b>(786)</b>	<b>890</b>
Basic EPS (cents)	114.0	(43.2)	83.4
Diluted EPS (cents)	113.8	(43.2)	83.3

<b>Balance sheet</b>			
<b>€m</b>	<b>30-Jun-08</b>	<b>31-Dec-08</b>	<b>30-Jun-09</b>
<b>Assets</b>			
Cash and balances at central banks	1,144	2,466	2,084
Loans and receivables to banks	9,376	6,266	4,954
Derivatives	4,248	7,328	5,736
Loans and advances to customers	132,814	129,489	129,031
Financial investments and trading portfolio	29,585	30,924	31,951
Associates	1,631	1,999	1,675
Goodwill and intangibles	707	774	748
Other assets	3,494	2,928	3,361
<b>Total assets</b>	<b>182,999</b>	<b>182,174</b>	<b>179,540</b>
<b>Liabilities</b>			
Deposits by banks	28,002	25,578	44,987
Customer accounts	86,983	92,604	82,710
Derivatives	4,461	6,468	5,356
Debt securities in issue	43,329	37,814	24,453
Subordinated debt and other capital instr	5,090	4,526	4,683
Other liabilities	4,158	4,871	5,242
<b>Total liabilities</b>	<b>172,023</b>	<b>171,861</b>	<b>167,431</b>
Shareholders' equity	9,581	8,969	11,553
Minority interests	1,395	1,344	556
<b>Total liabilities and shareholders' equ</b>	<b>182,999</b>	<b>182,174</b>	<b>179,540</b>
Number of employees *	25,968	25,873	25,048

\* Based on actual headcount as at 25th of June 08, Dec 08 and June 09. Includes temporary students and excludes all staff on unpaid leave (c400 to c500 at any one time)

### Loan book by sector

Loan book development							
€m	31-Dec-03	31-Dec-04	31-Dec-05	31-Dec-06	31-Dec-07	31-Dec-08	30-Jun-09
Property and Construction	11,088	16,384	24,934	35,150	46,410	47,926	49,931
Mortgages	13,158	16,803	21,396	26,644	30,101	31,625	32,629
Consumer lending	4,630	5,668	7,090	8,752	9,899	8,971	8,810
Corporate / SME	22,238	26,744	32,767	37,602	42,306	43,641	42,541
<b>Gross total</b>	<b>51,114</b>	<b>65,599</b>	<b>86,187</b>	<b>108,148</b>	<b>128,716</b>	<b>132,163</b>	<b>133,911</b>
Less unearned income and pro	(777)	(787)	(955)	(1,033)	(1,113)	(2,674)	(4,880)
<b>Total</b>	<b>50,337</b>	<b>64,812</b>	<b>85,232</b>	<b>107,115</b>	<b>127,603</b>	<b>129,489</b>	<b>129,031</b>

### Split of gross loan book (30 June 2009)

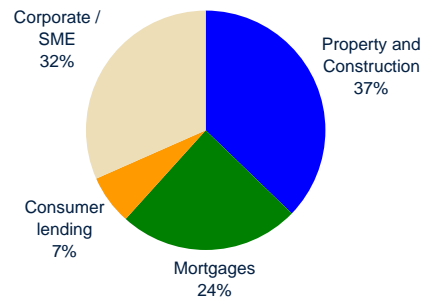

### Evolution of total gross loan book (€m)

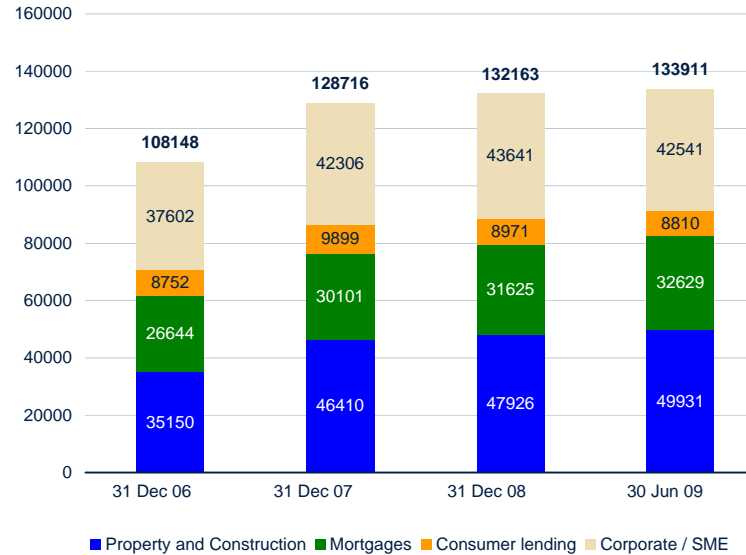

Loan Book by geography

Geographic breakdown of loan book

€m, 30 June 2009	Rep of Ireland	UK	Poland	North America	rest of the World	Total
Property and Construction	34,442	11,276	2,724	1,029	460	49,931
Mortgages	27,381	3,835	1,318	-	95	32,629
Consumer lending	6,923	979	908	-	-	8,810
Corporate / SME	24,378	11,976	3,440	1,951	796	42,541
<b>Gross total</b>	<b>93,124</b>	<b>28,066</b>	<b>8,390</b>	<b>2,980</b>	<b>1,351</b>	<b>133,911</b>
Less unearned income and provis!	(3,781)	(763)	(284)	(27)	(25)	(4,880)
<b>Total</b>	<b>89,343</b>	<b>27,303</b>	<b>8,106</b>	<b>2,953</b>	<b>1,326</b>	<b>129,031</b>
<b>% of total</b>	<b>69.2%</b>	<b>21.2%</b>	<b>6.3%</b>	<b>2.3%</b>	<b>1.0%</b>	<b>100.0%</b>

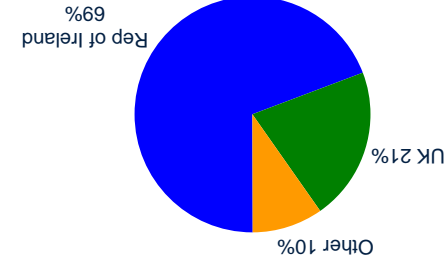

Split of loan book by region (30 June 2009)

**Land & Development**

	<b>Dec-08</b>	<b>Jun-09</b>
	<b>€m</b>	<b>€m</b>
Ireland	16,855	17,062
UK	3,702	3,947
US	742	654
Other	1,343	1,326
<b>Total</b>	<b>22,642</b>	<b>22,989</b>

**Geographic breakdown of L&D book as at 30 June 2009**

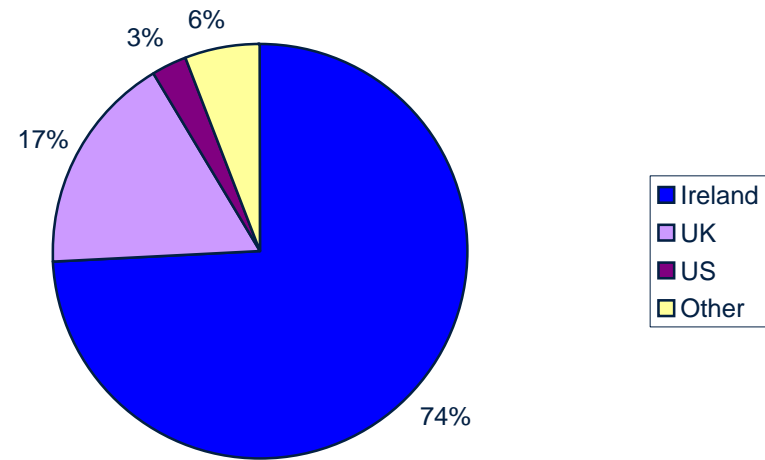

Loan book quality

Critised loans summary	
€m	30-Jun-09
Watch loans	8,172
Vulnerable loans	4,302
Impaired loans	2,991
Total criticised loans	15,465
% of total gross loans	11.7%
	33,394
	25.0%

Impaired loans by divisions	
€m	31-Dec-08
AIB Bank ROI	1,862
Capital markets	338
AIB Bank UK	522
CEE	269
Total impaired loans	2,991
% of total gross loans	2.3%
	10,804
	8.1%

Provisions for impairment of loans and receivables	
€m	31-Dec-08
Property and Construction	556
Mortgages	47
Consumer lending	180
Corporate / SME	365
IBNR	1,146
Total provisions	2,294
% of gross loan book	1.7%
	4,550
	3.4%

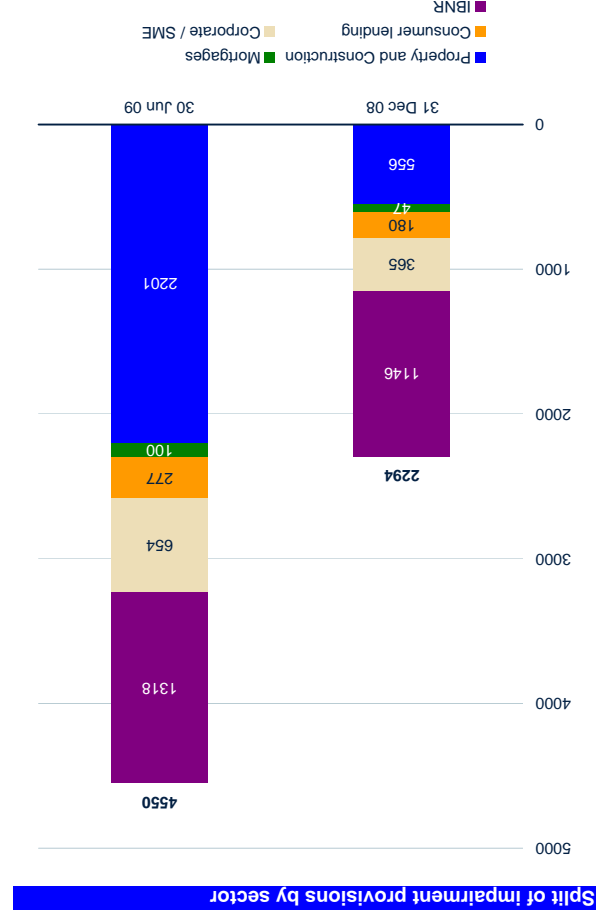

### Deposits breakdown

Geographic breakdown of customer deposits			
€m	30-Jun-08	31-Dec-08	30-Jun-09
Rep of Ireland	51,157	59,653	54,172
UK	21,928	20,656	16,723
Poland	9,984	10,239	9,334
North America	3,914	1,936	2,202
Rest of world	-	120	279
<b>Total</b>	<b>86,983</b>	<b>92,604</b>	<b>82,710</b>

Number of customer depositions			
	30-Jun-08	31-Dec-08	30-Jun-09
Rep of Ireland	2,388	2,460	2,497
UK	457	470	479
Poland	1,854	2,094	2,071
North America *	-	-	-
Rest of world #	-	-	-
<b>Total</b>	<b>4,699</b>	<b>5,024</b>	<b>5,047</b>

\* Number of customers less than 1,000, primarily large Corporate deposits through AIB Capital Markets  
 # Number of customers less than 1,000

### Split of deposits (€) by region (30 June 2009)

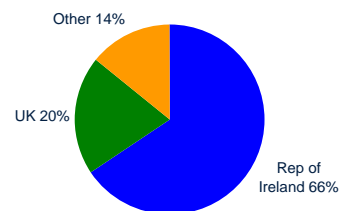

Capital ratios

Capital ratios €m		30-Jun-08	31-Dec-08	30-Jun-09
Core Tier 1 capital	8,630	7,758	11,110	
Deductions and other items	2,120	2,179	(861)	
Tier 1 capital	10,750	9,937	10,249	
Tier 2 capital	4,046	4,258	3,895	
Total capital	14,635	14,053	14,016	
Risk weighted assets	138,383	133,899	131,327	
Core tier 1 ratio	6.2%	5.8%	8.5%	
Tier 1 ratio	7.8%	7.4%	7.8%	
Total capital ratio	10.6%	10.5%	10.7%	

Source: June 2009 half-year interim report

### Subordinated debt buy back

Core Tier 1 capital of €1,072 million was generated in June 2009 through the exchange of 10 year dated Sterling and Euro Subordinated Debt instruments for six existing issues of Non- Upper Tier 2 Instruments

The existing note holders exchanged their notes at discounts ranging from 33% to 50% and participation rates ranged from 52% to 90%.

Four of the instruments are recorded as liabilities in the balance sheet and a gain of €580 million after taxation was recorded in the income statement.

Two of the Instruments were recorded as Equity in the Balance Sheet and a gain of €492 million after taxation was recorded in the statement of comprehensive income.

Debt Exchange	Tier 2 Debt	Non Core Tier 1	Core Tier 1
	€m	€m	
Before buy back	3,886	2,395	
New Debt issued	1,205	-	
Boughtback / Exchanged	(546)	(1,828)	
After buy back	4,545	567	
Profit made on exchange / buyback			1,072

### Bank capital ratios

€m	Before buy back	After buyback
<b>Core Tier 1 capital</b>	10,038	11,110
Deductions and other items	967	(861)
<b>Tier 1 capital</b>	11,005	10,249
Tier 2 capital	3,108	3,767
<b>Total capital</b>	14,113	14,016
Risk weighted assets	131,327	131,327
<b>Core tier 1 ratio</b>	<b>7.6%</b>	<b>8.5%</b>
<b>Tier 1 ratio</b>	<b>8.4%</b>	<b>7.8%</b>
<b>Total capital ratio</b>	<b>10.7%</b>	<b>10.7%</b>

**AIB Residential Mortgage Lending (Comparison between September 2008 and June 2009)**

<b>AIB ROI Division</b>		<b>Sep-08</b>		<b>Jun-09</b>	
Total Residential Mortgage Approvals	no.	1,735	391	1,486	333
Total Residential Mortgage Drawdown	no.	1,705	380	1,398	295
<b>First Time Buyers (included above)</b>					
Residential Mortgage Approvals (letter of offer issued)	no.	270	64	378	87
Residential Mortgage Drawdown	no.	266	61	378	86

Share price performance (€)

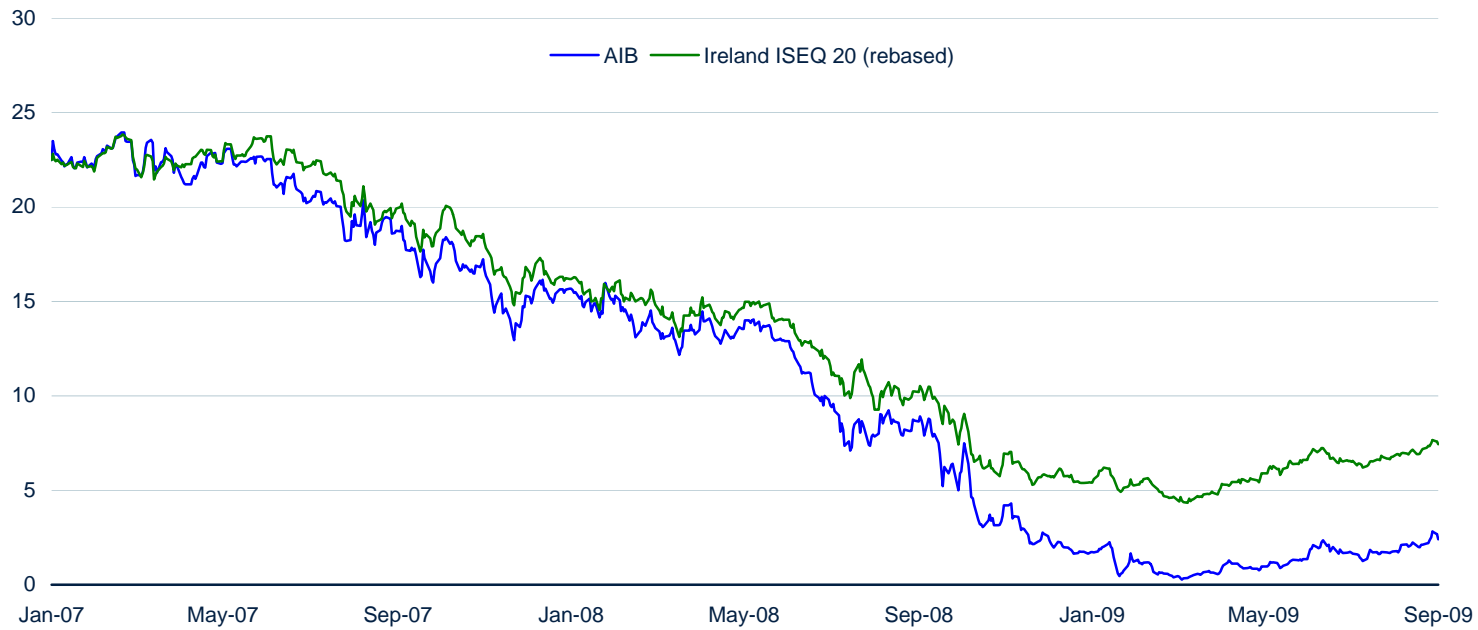

Source: Factset

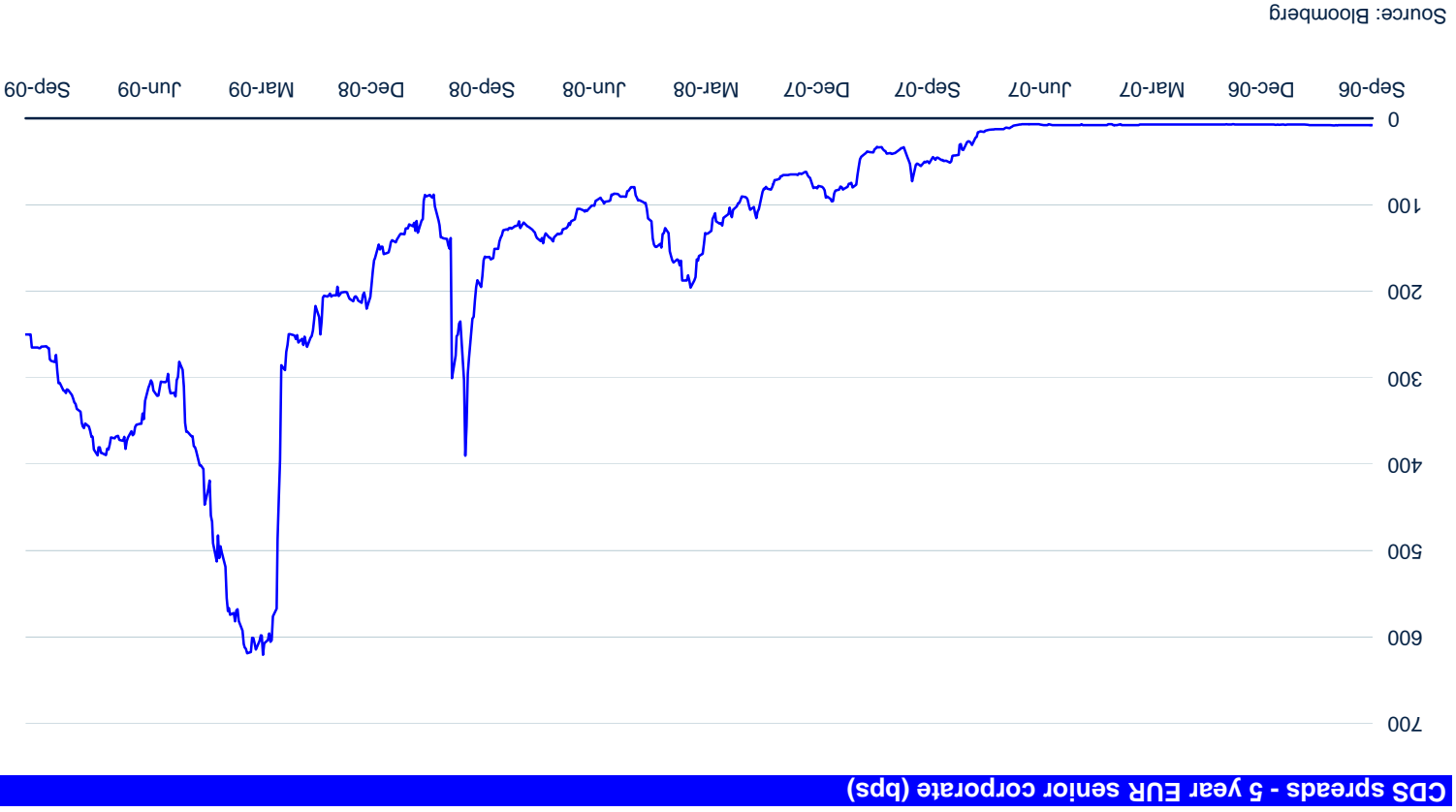

Source: Bloomberg

CDS spreads - 5 year EUR senior corporate (bps)

## AIB Indicative Funding Profile - Interim Results 30 June 2009

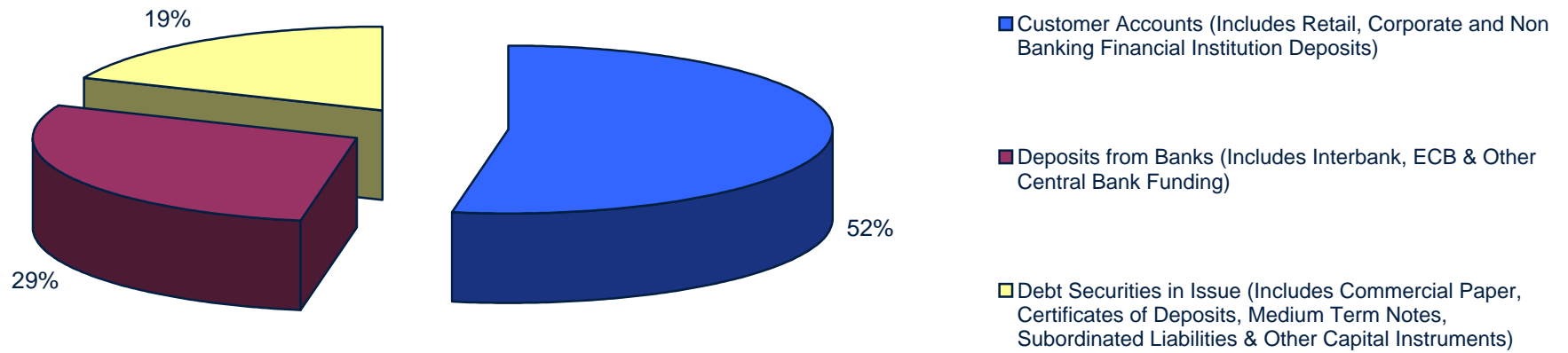

The information in this document has been confirmed by the institution to which it relates for this publication.

## **BOI INFORMATION PACK**

<b>Profit and Loss Account</b>			
<b>€m</b>	<b>YE 31 March 08</b>	<b>6m to 30 Sep 08</b>	<b>YE 31 March 09</b>
Net interest income	3,263	1,949	3,670
Non interest income	658	9	251
Insurance income (net of claims)	316	101	36
<b>Total operating income</b>	<b>4,237</b>	<b>2,059</b>	<b>3,957</b>
Other operating expenses	(2,157)	(1,036)	(2,105)
Impairment of goodwill and intangibles	-	-	(304)
<b>Total operating expenses</b>	<b>(2,157)</b>	<b>(1,036)</b>	<b>(2,409)</b>
<b>Operating profit before provisions</b>	<b>2,080</b>	<b>1,023</b>	<b>1,548</b>
Provision for impairments	(232)	(307)	(1,513)
<b>Operating profit</b>	<b>1,848</b>	<b>716</b>	<b>35</b>
Income from associates	46	(10)	(42)
Other items	39	-	-
<b>Profit before tax</b>	<b>1,933</b>	<b>706</b>	<b>(7)</b>
Tax	(229)	(95)	41
<b>Profit after tax</b>	<b>1,704</b>	<b>611</b>	<b>34</b>
Basic EPS (cents)	174.6	63.5	5.9
Diluted EPS (cents)	173.9	63.5	5.9

<b>Balance sheet</b>			
<b>€m</b>	<b>30 Sep 08</b>	<b>31 March 08</b>	<b>31 March 09</b>
<b>Assets</b>			
Cash and balances at central banks	1,652	484	3,224
Loans and receivables to banks	8,416	9,409	7,886
Derivatives	4,412	4,568	8,397
Loans and advances to customers	144,289	135,738	133,740
Financial assets and trading portfolio	38,343	40,335	34,587
Associates	239	98	173
Goodwill and intangibles	884	863	532
Other assets	6,044	5,939	5,577
<b>Total assets</b>	<b>204,279</b>	<b>197,434</b>	<b>194,116</b>
<b>Liabilities</b>			
Deposits by banks	16,920	14,130	28,814
Customer accounts	90,665	86,234	83,119
Derivatives	3,383	4,322	7,554
Debt securities in issue	60,740	60,842	45,133
Subordinated debt and other capital instruments	8,476	7,808	7,942
Insurance contract liabilities	6,849	7,140	5,634
Liabilities to customers under investment contracts	5,440	5,662	4,084
Other liabilities	5,373	4,774	4,923
<b>Total liabilities</b>	<b>197,846</b>	<b>190,912</b>	<b>187,203</b>
Shareholders' equity	6,382	6,484	6,852
Minority interests	51	38	61
<b>Total liabilities and shareholders' equity</b>	<b>204,279</b>	<b>197,434</b>	<b>194,116</b>
Number of employees	15,962	16,026	15,868

## Loan book by sector

### Loan book development (gross)

€m	31/03/2003 *	31/03/2004 *	31-Mar-05	31-Mar-06	31-Mar-07	31-Mar-08	30-Sep-08	31-Mar-09
Property and Construction	6,650	10,813	14,535	20,378	29,695	35,596	38,000	33,955
Residential Mortgages	30,868	36,433	41,339	50,998	59,689	60,761	63,400	58,888
Consumer - unsecured	4,020	5,088	6,383	7,564	8,954	9,409	5,900	5,637
Corporate / SME	15,829	15,678	17,898	22,665	27,138	30,568	37,800	37,041
<b>Total</b>	<b>57,367</b>	<b>68,012</b>	<b>80,155</b>	<b>101,605</b>	<b>125,476</b>	<b>136,334</b>	<b>145,100</b>	<b>135,521</b>

\* 31 March 2003 and 31 March 2004 are Irish GAAP numbers.

### Pie chart with split of loan book (31 Mar 09)

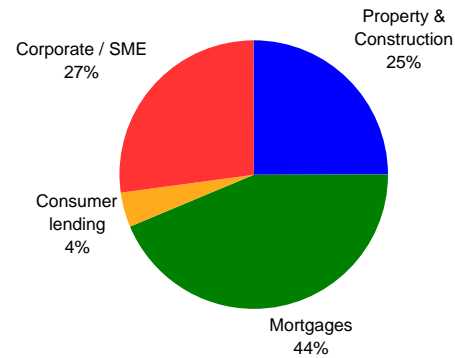

### Evolution of total gross loan book (€m)

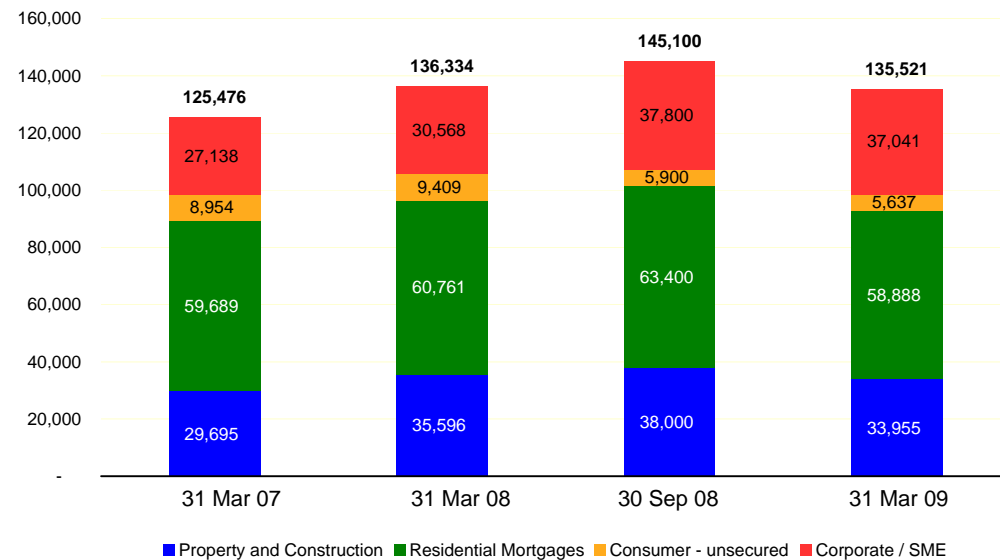

Loan Book by geography

<b>Geographic breakdown of gross loan book</b>			
<b>€m, 31 March 2009</b>			
	<b>Ireland</b>	<b>UK &amp; other</b>	<b>Total</b>
Property and Construction	19,358	14,597	33,955
Mortgages	27,647	31,241	58,888
Consumer lending	3,406	2,231	5,637
Corporate / SME	27,537	9,504	37,041
<b>Total</b>	<b>77,948</b>	<b>57,573</b>	<b>135,521</b>
<b>% of total</b>	<b>57.5%</b>	<b>42.5%</b>	<b>100.0%</b>

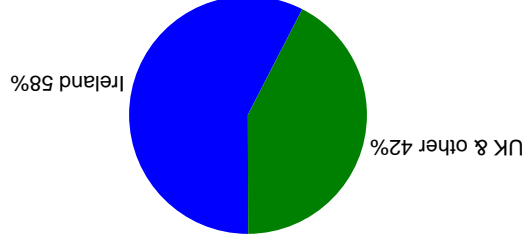

**Split of gross loan book by region (30 June 2009)**

**Geographic Breakdown of BOI's Land and Development book**

	<b>30.9.08</b>	<b>31.03.09</b>
	<b>€m</b>	<b>€m</b>
Ireland	7,100	6,800
UK	6,000	5,200
US	-	-
Other	-	-
<b>Total</b>	<b>13,100</b>	<b>12,000</b>

**Geographic Breakdown of BOI's Land and Development book as at 31st March 2009**

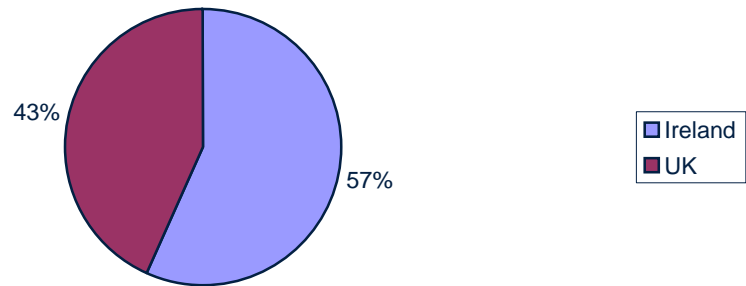

Loan book quality

Loan book grade profile	
€m	31 March 08
High quality	77,952
Satisfactory quality	47,091
Acceptable quality	6,527
Lower quality but not past due nor impaired	683
<b>Neither past due nor impaired</b>	<b>132,253</b>
Past due but not impaired	3,019
Impaired loans	1,062
<b>Past due or impaired loans</b>	<b>4,081</b>
<b>Total loans and advances to customers</b>	<b>136,334</b>
% of past due or impaired loans	3.0%
€m	31 March 09
High quality	72,465
Satisfactory quality	37,087
Acceptable quality	12,556
Lower quality but not past due nor impaired	2,330
<b>Neither past due nor impaired</b>	<b>124,438</b>
Past due but not impaired	5,761
Impaired loans	5,322
<b>Past due or impaired loans</b>	<b>11,083</b>
<b>Total loans and advances to customers</b>	<b>135,521</b>
% of past due or impaired loans	8.2%

Impaired loans by sector	
€m	31 March 08
Property and Construction	310
Residential Mortgages	15
Consumer - unsecured	231
Corporate / SME	506
<b>Total impaired loans</b>	<b>1,061</b>
% of total gross loans	0.8%
€m	31 March 09
Property and Construction	3,538
Residential Mortgages	229
Consumer - unsecured	368
Corporate / SME	1,187
<b>Total impaired loans</b>	<b>5,322</b>
% of total gross loans	3.9%

Impairment provisions	
€m	31 March 08
<b>Total loan impairment provisions</b>	<b>596</b>
% of gross loan book	0.4%
€m	31 March 09
<b>Total loan impairment provisions</b>	<b>1,781</b>
% of gross loan book	1.3%

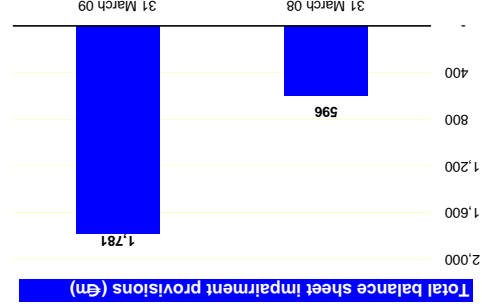

### Deposits breakdown

#### Breakdown of customer deposits by division

€bn	31 March 08	31 March 09
Retail Rep of Ireland		
– deposits	21	23
– current accounts	12	10
Capital Markets	32	29
UK Financial Services	21	21
<b>Total</b>	<b>86</b>	<b>83</b>

#### Number of customer deposits

000	31 March 08	31 March 09
Retail Rep of Ire		
– deposits	1,300	1,310
– current accounts (active)	1,070	1,090
Capital Markets (estimated)	1	1
UK Financial Services (including UK Post Office)	740	1,100
<b>Total</b>	<b>3,111</b>	<b>3,501</b>

#### Split of deposits (€) by region (31 March 2009)

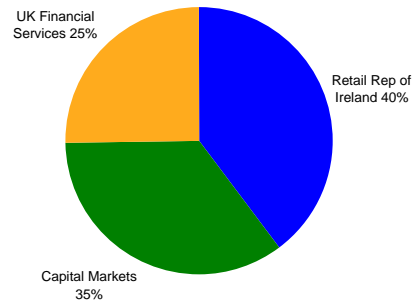

Capital ratios

Capital ratios	31 March 08	30 Sep 08	31 March 09
Equity Tier 1 capital	6.6	nd	6.5
Core Tier 1 capital	6.6	7.3	10.0
Tier 1 capital	9.4	10.1	12.6
Total capital	13.0	14.2	16.0
Risk weighted assets	117	116	105
Equity tier 1 ratio	5.6%	na	6.2%
Core tier 1 ratio	5.7%	6.3%	9.5%
Tier 1 ratio	8.1%	8.7%	12.0%
Total capital ratio	11.1%	12.2%	15.2%

### Subordinated debt buy back

#### Comment

The BOI debt buyback involved a cash tender offer for 6 Tier 1 securities at an average price of 41% of their face value.

The profit obtained from the buyback increased Equity Tier 1 and Core Tier 1 by circa €1 billion.

Total Tier 1 and Total Capital fell by €0.7 billion due to the fact that €1.7 billion of notes were bought back for a profit of €1 billion.

### Debt Buyback

	€m
Subordinated debt before buy back as at March 09	7,942
Subordinated debt after buy back pro forma as at March 09	6,283
Profit made on subordinated debt buyback	1,000

### Bank capital ratios

€m	Before buy back March 09	After buyback Pro forma March 09
<b>Core Tier 1 capital</b>	10,026	11,026
Deductions and other items		
<b>Tier 1 capital</b>	12,649	11,908
Tier 2 capital	4,071	4,071
<b>Total capital</b>	15,971	15,230
Risk weighted assets	105,377	105,377
<b>Core tier 1 ratio</b>	9.50%	10.50%
<b>Tier 1 ratio</b>	12.00%	11.30%
<b>Total capital ratio</b>	15.20%	14.50%

**Mortgage Lending (Comparison between September 2008 and June 2009)**

	Sept. '08		June '09	
	No.	€m	No.	€m
Approvals*	1,354	€261.78m	1,660	€316.55m
Drawdowns	1,318	€278.56m	999	€162.53m

FTB	Sept. '08		June '09	
	No.	€m	No.	€m
Approvals*	292	€68.87m	492	€107.22m
Drawdowns	282	€64.48m	308	€59.76m

\*Approvals relate to applications that were approved in this period, i.e. they do not correlate to all applications in the period, only those applications that were approved.

An approved application may not translate into a drawdown, or may take considerable time to translate into a drawdown, due to cancellations, phased drawdowns, customers shopping around, etc.

In addition, BCI approve applications for our direct branch channel very early in the application process, subject to a number of conditions. If these conditions are not met, or info. submitted at application stage changes, approvals/letters of offer may be withdrawn and/or amended.

Share price performance (€)

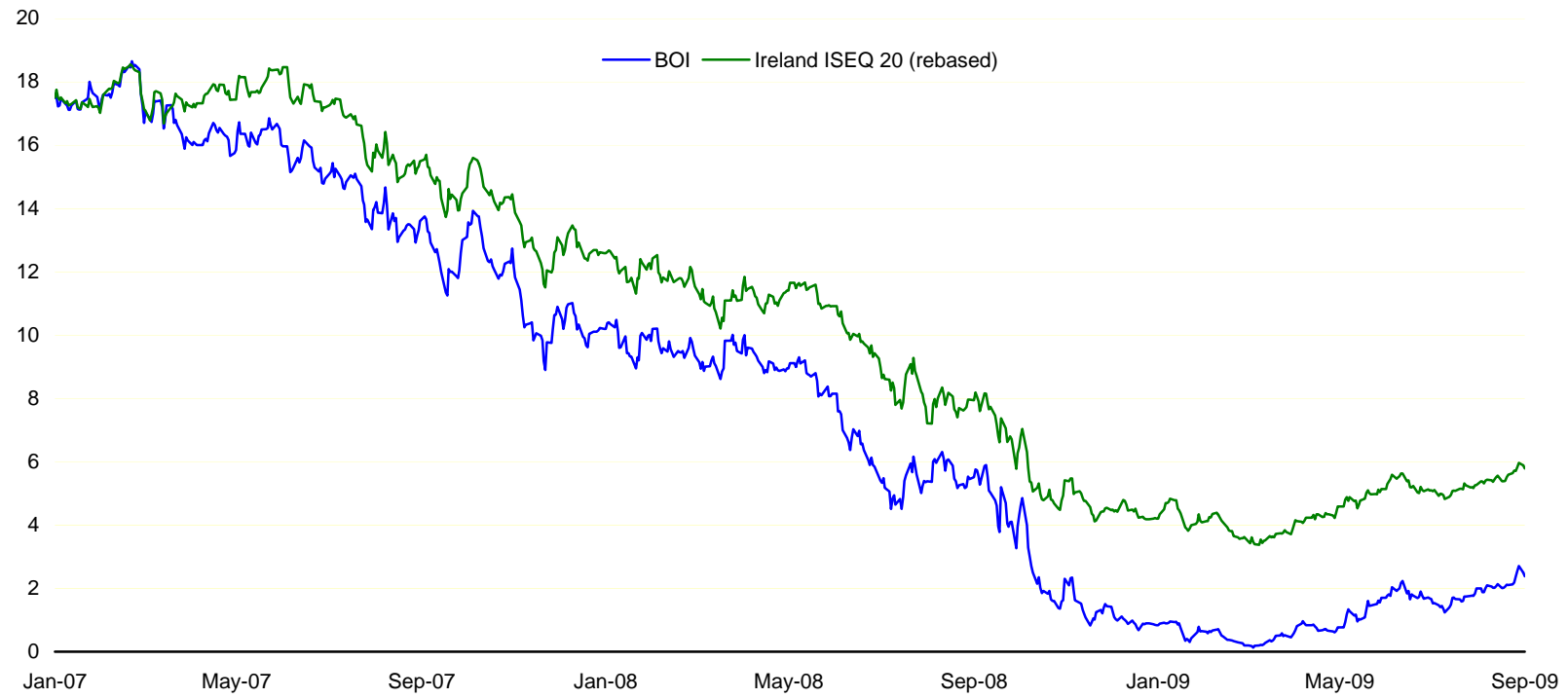

Source: Factset

**CDS spreads - 5 year EUR senior corporate (bps)**

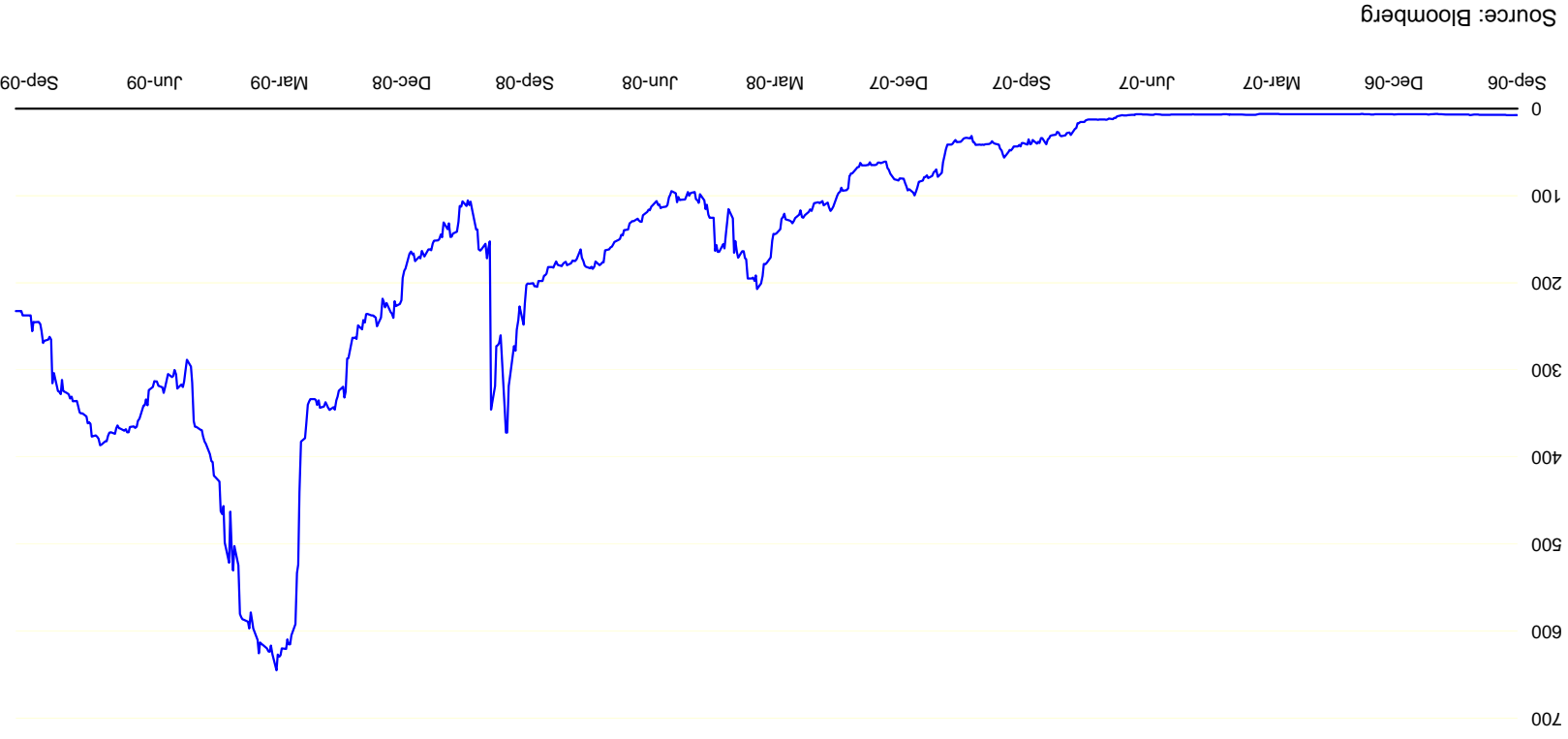

## Bank of Ireland Indicative Funding Profile - Annual Report 31 March 2009

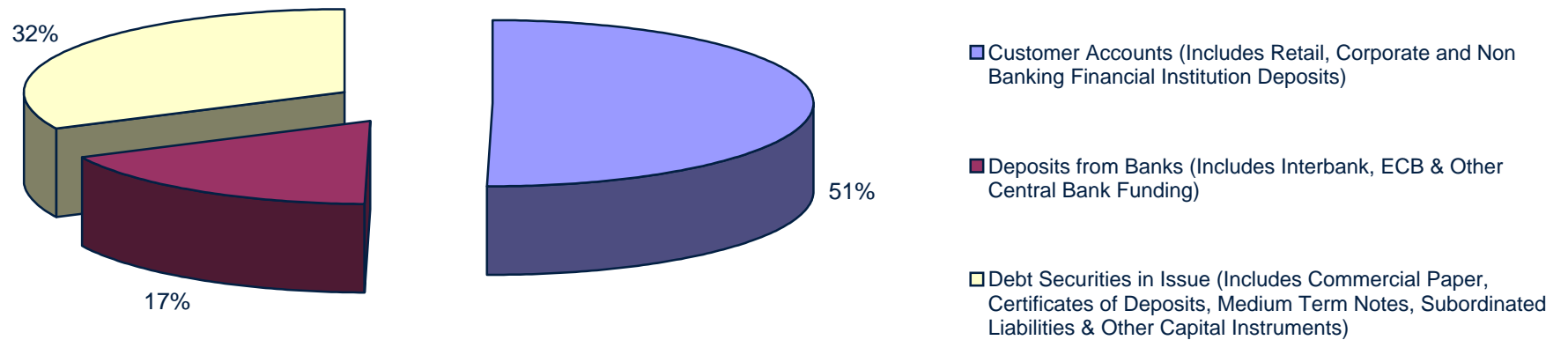

**ANGLO INFORMATION PACK**

## Income Statement

Income Statement			
€m	12 mths to 30 Sep 07	12 mths to 30 Sep 08	6 mths to 31 Mar 09
Net interest income	1,566	1,888	856
Other income / (expense)	195	84	(416)
<b>Total operating income</b>	<b>1,761</b>	<b>1,972</b>	<b>440</b>
Administrative expenses	(368)	(301)	(135)
Other expenses	(25)	(27)	(10)
<b>Total operating expenses</b>	<b>(393)</b>	<b>(328)</b>	<b>(145)</b>
<b>Operating profit before provisions</b>	<b>1,368</b>	<b>1,644</b>	<b>295</b>
Provision for impairments - loans and advances to customers	(82)	(724)	(4,105)
Provision for impairments - investment securities and property	(67)	(155)	(230)
<b>Operating profit / (loss)</b>	<b>1,219</b>	<b>765</b>	<b>(4,040)</b>
Income from associates and joint ventures	2	(1)	(126)
Other items	22	20	49
<b>Profit / (loss) before tax</b>	<b>1,243</b>	<b>784</b>	<b>(4,117)</b>
Tax	(235)	(120)	335
<b>Profit / (loss) after tax</b>	<b>1,008</b>	<b>664</b>	<b>(3,782)</b>

Balance Sheet

	€m		
	31-Mar-09	30-Sep-08	30-Sep-07
<b>Balance Sheet</b>			
<b>Assets</b>			
Cash and balances with central banks	266	1,822	848
Loans and advances to banks	6,698	14,002	12,051
Derivative financial instruments	4,708	1,995	1,355
Loans and advances to customers	66,638	72,151	65,949
Financial assets	7,927	8,391	12,960
Associate and Joint Ventures	147	300	88
Goodwill and intangibles	20	21	63
Assets in respect of linked liabilities to customers under investme	1,384	2,265	2,734
Other assets	754	374	604
<b>Total assets</b>	<b>88,542</b>	<b>101,321</b>	<b>96,652</b>
<b>Liabilities</b>			
Deposits by banks	30,478	20,453	7,601
Customer accounts	34,106	51,499	52,686
Derivative financial instruments	4,017	1,490	1,175
Debt securities in issue	14,228	17,280	23,588
Liabilities to customers under investment contracts	469	1,191	1,779
Subordinated liabilities and other capital instruments	4,945	4,948	5,274
Other liabilities	198	328	484
<b>Total liabilities</b>	<b>88,441</b>	<b>97,189</b>	<b>92,587</b>
Shareholders' equity	99	4,125	4,052
Minority interests	2	7	13
<b>Total equity and liabilities</b>	<b>88,542</b>	<b>101,321</b>	<b>96,652</b>
Average number of employees	1,753	1,864	1,714

## Loan book by sector

### Loan book development

€bn	30-Sep-03	30-Sep-04	30-Sep-05	30-Sep-06	30-Sep-07	30 Sep 08	31 Mar 09
Ireland	10.2	13.4	19.7	28.8	38.0	43.3	43.3
UK	7.0	10.0	12.6	17.3	21.8	21.4	18.7
US	1.2	1.3	2.5	4.4	7.6	9.4	10.3
<b>Total loan book</b>	<b>18.4</b>	<b>24.7</b>	<b>34.8</b>	<b>50.5</b>	<b>67.4</b>	<b>74.1</b>	<b>72.3</b>

Note - Basis of preparation - 2003-2004 Irish GAAP, 2005 pro-forma IFRS, 2006-2009 IFRS. Balances are shown gross of impairment provisions, inclusive of lending to policyholders in respect of investment contracts and also securitised loans

### Sectoral analysis of loan book (31 Mar 2009)

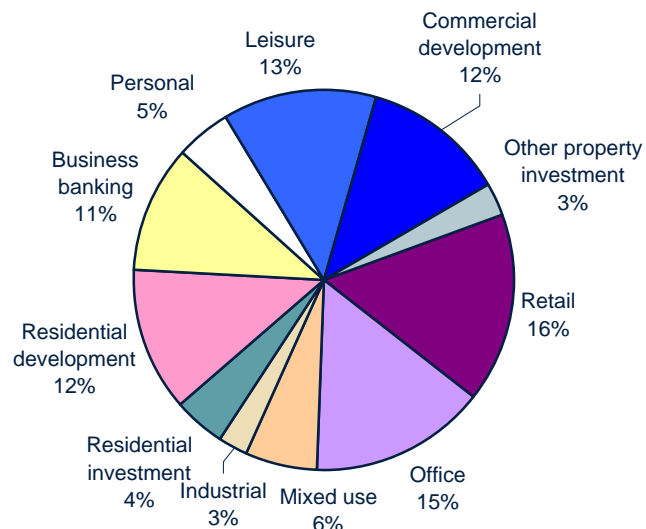

### Evolution of gross loan book €bn

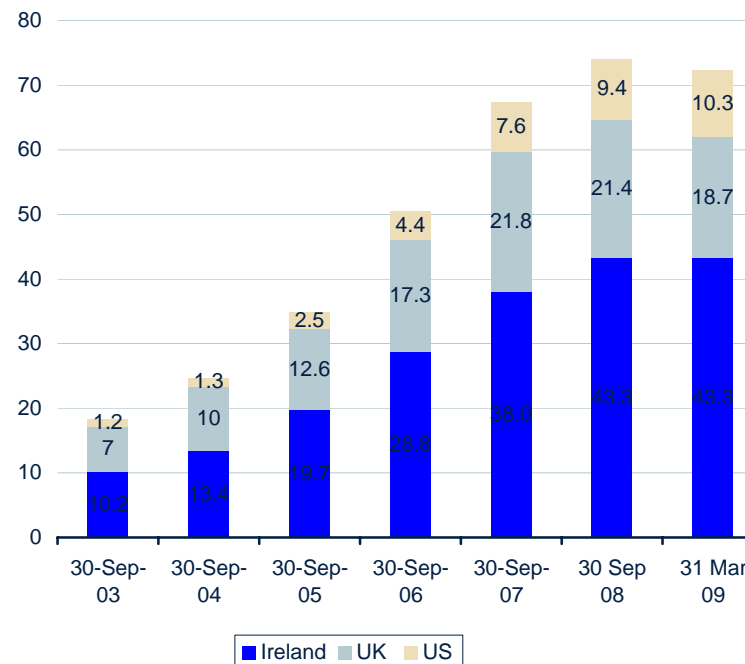

Sectoral Analysis	31 Mar 09
Retail	16%
Office	15%
Mixed use	6%
Industrial	3%
Residential investment	4%
Residential development	12%
Business banking	11%
Personal	5%
Leisure	13%
Commercial development	12%
Other property investment	3%
<b>Total</b>	<b>100%</b>

Loan Book by geography

**Geographic breakdown of loan book**

	Rep of Ireland	UK	USA	Total
Investment, business banking & ot	31.6	14.0	9.0	54.6
Commercial development	5.7	2.4	0.8	8.9
Residential development	6.0	2.3	0.5	8.8
<b>Total gross loans</b>	<b>43.3</b>	<b>18.7</b>	<b>10.3</b>	<b>72.3</b>
<b>% of total</b>	<b>59.9%</b>	<b>25.9%</b>	<b>14.2%</b>	<b>100.0%</b>

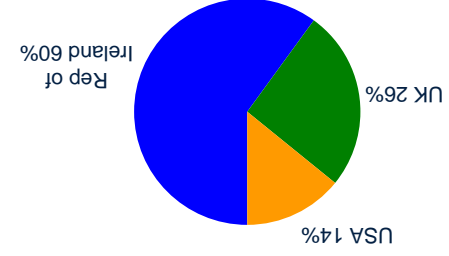

**Split of loan book by region (March 2009)**

## Land & Development

	30.9.08	31.3.09
	€m	€m
Ireland	10.4	10.7
UK	5.8	4.9
US	1.4	1.4
Other	0.7	0.7
<b>Total</b>	<b>18.3</b>	<b>17.7</b>

### Land Development Loan Book as at 31st March 2009

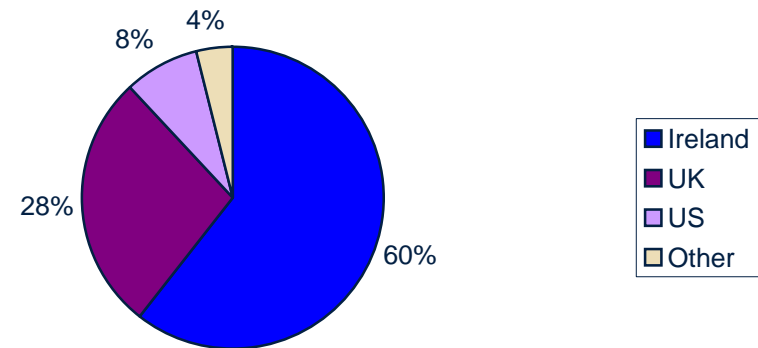

Loan book quality

Asset quality summary		30-Sep-08	31 Mar 09
€m			
Good quality		62,294	39,287
Satisfactory quality		6,302	4,078
Lower quality but not past due nor impaired		2,736	5,274
Past due but not impaired		1,782	12,906
Impaired		957	10,706
Total past due or impaired loans		2,739	23,612
Total gross loans		74,071	72,251
% of past due or impaired loans		3.7%	32.7%

Impaired loans by class of asset		30-Sep-08	31 Mar 09
€m			
Commercial		146	5,549
Residential		719	3,388
Business banking		16	512
Other lending		76	1,257
Total impaired loans		957	10,706
% of total gross loans		1.3%	14.8%

Provisions for impairment on loans and advances		30-Sep-08	31 Mar 09
€m			
Specific		272	3,853
Collective		642	1,015
Total		914	4,868
% of total gross loans		1.2%	6.7%

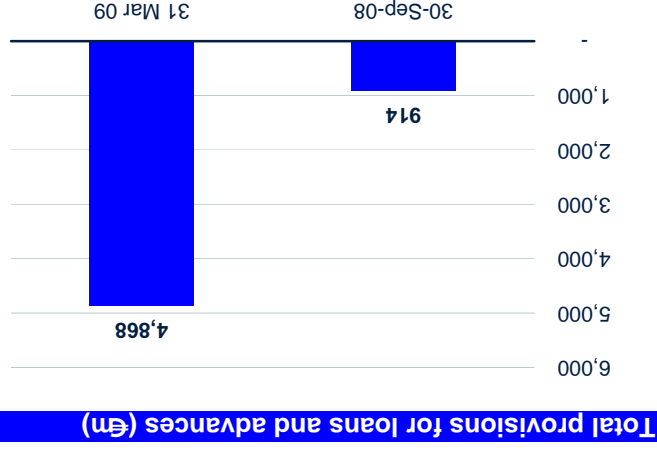

## Customer deposits breakdown

<b>Geographic breakdown of customer deposits</b>		
<b>€m</b>	<b>30-Sep-08</b>	<b>31-Mar-09</b>
Rep of Ireland	21,318	11,620
UK	20,247	13,161
Rest of world	9,934	9,325
<b>Total</b>	<b>51,499</b>	<b>34,106</b>

---

<b>Number of customer deposits</b>		
<b>000</b>	<b>30-Sep-08</b>	<b>31-Mar-09</b>
Rep of Ireland	71	69
UK	156	205
Rest of world	24	15
<b>Total</b>	<b>251</b>	<b>289</b>

---

## Capital ratios

Capital ratios		€m
	30-Sep-08	31-Mar-09
Regulatory core Tier 1 capital	5,068	1,089
Tier 1 capital	7,201	3,120
Total capital	10,318	6,577
Risk weighted assets	85,798	80,175
Core tier 1 ratio	5.9%	1.4%
Tier 1 ratio	8.4%	3.9%
Total capital ratio	12.0%	8.2%

As disclosed in the Bank's Interim Report for the six months ended 31 March 2009, the capital position at 31 March 2009 benefited as a result of temporary derogations from certain regulatory capital requirements granted by the Financial Regulator. The figures are at the 31st March 2009 and do not include the impact of €3.8 billion injected into the Bank by the State or the impact of the buyback of certain debt instruments

Source: March 2009 half-year interim report

## Subordinated debt buy back

Debt Buyback	
	€m
Subordinated debt before buy back	4,892
Subordinated debt after buy back	2,392
Profit made on subordinated debt buyback	1,814

The subordinated debt amounts above are based on the nominal amounts. The profit made on the buyback is the profit arising from repurchasing the debt at a discount to par and is stated before tax and includes gains arising from the release of interest accruals and hedging adjustments.

# Anglo Indicative Funding Profile - Interim Report 31 March 2009

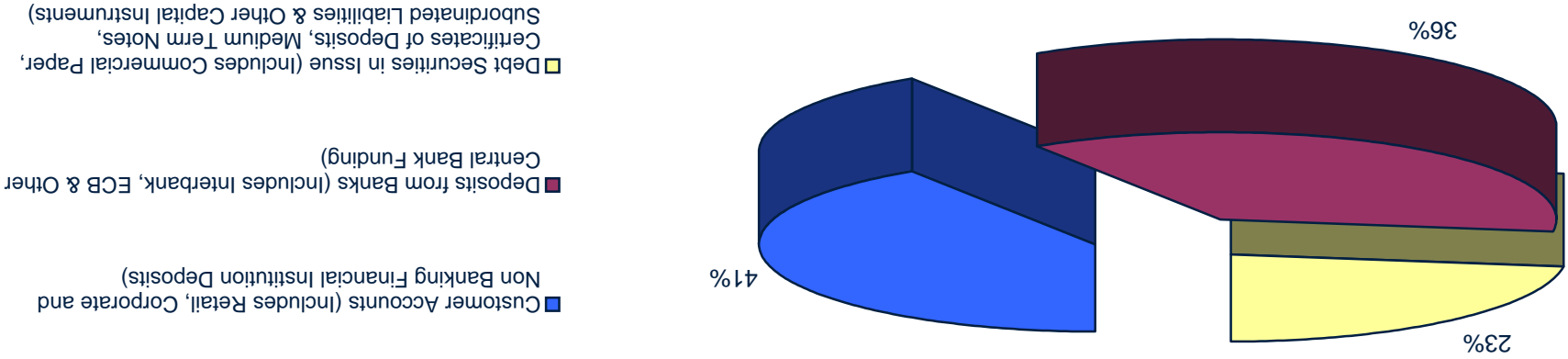



## **IL&P INFORMATION PACK**

The information in this document has been confirmed by the institution to which it relates for this publication. It is published for illustrative purposes only and should not be relied upon for any other purpose. The Minister for Finance, the Government of Ireland or their advisers have not independently verified the information and take no responsibility for its accuracy or completeness.

## Profit and Loss Account

€m	6m to 30 June 08	6m to 30 June 09	12m to 12 Dec 08
Net interest income	230	185	486
Net fee and commission income	(23)	(41)	(54)
Trading income	5	(6)	5
Premiums on insurance contracts (net of reinsur	278	355	441
Investment return	(3,366)	163	(7,741)
Fees from investment contracts & fund manager	149	111	272
Change in shareholder value of in-force busines	32	(89)	70
<b>Total operating income</b>	<b>(2,695)</b>	<b>678</b>	<b>(6,521)</b>
Claims on insurance contracts (new of reinsuran	(163)	(167)	(314)
Change in insurance contract liabilities (net of re	120	(79)	234
Change in investment contract liabilities	3,303	(169)	7,656
Investment expenses	(29)	(17)	(50)
Administrative expenses	(275)	(243)	(540)
Depreciation and amortisation	(25)	(26)	(50)
Impairment of goodwill	-	-	(170)
<b>Total operating expenses</b>	<b>2,931</b>	<b>(701)</b>	<b>6,766</b>
<b>Operating profit before provisions</b>	<b>236</b>	<b>(23)</b>	<b>245</b>
Provision for impairments - loans and receivable	(15)	(189)	(82)
Provision for impairments - debt securities	-	-	(122)
<b>Operating profit</b>	<b>221</b>	<b>(212)</b>	<b>41</b>
Income from associates	1	4	22
<b>Profit before tax</b>	<b>222</b>	<b>(208)</b>	<b>63</b>
Tax	(12)	(7)	(10)
<b>Profit after tax</b>	<b>210</b>	<b>(215)</b>	<b>53</b>
Attributable to non controlling interest	(2)	-	(4)
<b>Attributable to owners of parent</b>	<b>208</b>	<b>(215)</b>	<b>49</b>
Basic EPS (cents)	77.8	(80.4)	18.3
Diluted EPS (cents)	77.7	(80.4)	18.3

Balance Sheet

	30-Jun-09	31-Dec-08	30-Jun-08
<b>€m</b>			
<b>Balance sheet</b>			
<b>Assets</b>			
Cash and balances at central banks	274	200	141
Debt securities	12,183	10,929	8,974
Equity shares and units in unit trusts	11,028	10,390	14,558
Loans and receivables to banks	4,876	4,775	2,358
Derivatives	1,184	1,162	1,285
Loans and advances to customers	39,894	40,075	41,005
Associates	143	139	134
Goodwill and intangibles	126	125	259
Reinsurance assets	1,977	2,133	1,992
Shareholder value of in-force business	698	787	749
Other assets	3,451	3,634	4,675
<b>Total assets</b>	<b>75,834</b>	<b>74,349</b>	<b>76,130</b>
<b>Liabilities</b>			
Deposits by banks	20,644	18,546	11,540
Customer accounts	12,927	14,118	14,858
Derivatives	674	550	609
Debt securities in issue	11,265	10,899	14,564
Investment contract liabilities	21,430	21,118	25,158
Insurance contract liabilities	3,940	4,007	3,901
Subordinated liabilities	1,636	1,699	1,661
Other liabilities	1,168	1,064	1,185
<b>Total liabilities</b>	<b>73,684</b>	<b>72,001</b>	<b>73,476</b>
Shareholders' equity	2,150	2,347	2,639
Non controlling interest	-	1	15
<b>Total liabilities and shareholders' equity</b>	<b>75,834</b>	<b>74,349</b>	<b>76,130</b>
Number of employees	5,490		

### Loan book development

€m	31-Dec-03	31-Dec-04	31-Dec-05	31-Dec-06	31-Dec-07	31-Dec-08	30-Jun-09
ROI residential lending		14,553	17,781	23,081	26,359	27,931	27,664
UK residential lending		3,911	5,413	6,905	8,259	7,171	7,907
Consumer finance		1,419	1,658	1,977	2,272	2,381	2,077
Commercial lending		1,124	1,235	1,494	1,862	1,978	1,962
Other		8	150	161	249	352	214
<b>Gross total</b>		<b>21,015</b>	<b>26,237</b>	<b>33,618</b>	<b>39,001</b>	<b>39,813</b>	<b>39,824</b>
Provisions for loan impairment		(46)	(52)	(57)	(75)	(139)	(316)
Deferred fees, discounts and fair value adjustments		164	155	171	194	401	386
<b>Total</b>	<b>16,028</b>	<b>21,133</b>	<b>26,340</b>	<b>33,732</b>	<b>39,120</b>	<b>40,075</b>	<b>39,894</b>

### Split of loan book (30 June 2009)

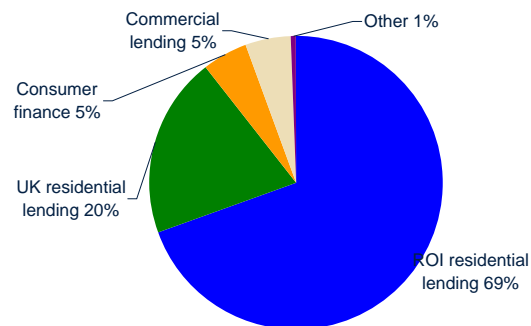

### Evolution of net loan book €m (post provisions and other adjustments)

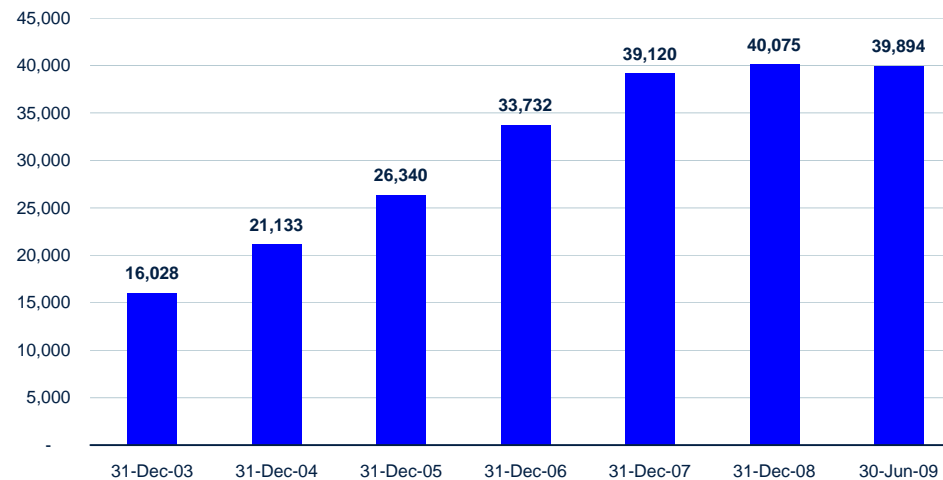

Loan Book by geography

**€m, 30 June 2009**

	Rep of Ireland	UK	Total
Residential lending	27,664	7,907	35,571
Consumer finance	2,077	-	2,077
Commercial lending	1,962	-	1,962
Other	214	-	214
<b>Gross total</b>	<b>31,917</b>	<b>7,907</b>	<b>39,824</b>
Provisions for loan impairment	(36)	(280)	(316)
Deferred fees, discounts and fair value adjustments	386	-	386
<b>Total</b>	<b>32,267</b>	<b>7,627</b>	<b>39,894</b>
<b>% of total</b>	<b>80.9%</b>	<b>19.1%</b>	<b>100.0%</b>

Source: IL&P H1 June 2009 interim report page 9

**Split of residential loan book by region (June 2009)**

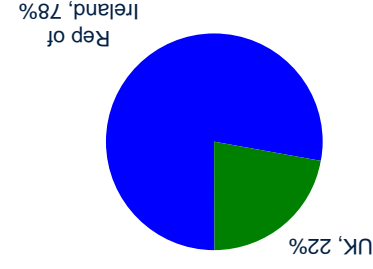

### Loan book quality

Loan book credit quality profile		
€m	31-Dec-08	30-Jun-09
Excellent risk profile	27,458	26,848
Satisfactory risk profile	7,567	7,231
Fair risk profile	2,243	2,545
<b>Neither past due nor impaired</b>	<b>37,268</b>	<b>36,624</b>
Past due but not impaired	2,343	2,758
Impaired	202	442
<b>Total past due or impaired loans</b>	<b>2,545</b>	<b>3,200</b>
<b>Total gross loans</b>	<b>39,813</b>	<b>39,824</b>
<b>% of past due or impaired loans</b>	<b>6.4%</b>	<b>8.0%</b>

Impaired loans by division		
€m	31-Dec-08	30-Jun-09
ROI residential lending	51	227
UK residential lending	74	75
Consumer finance	61	73
Commercial lending	16	67
<b>Total impaired loans</b>	<b>202</b>	<b>442</b>
<b>% of total gross loans</b>	<b>0.5%</b>	<b>1.1%</b>

Breakdown of total provisions		
€m	31-Dec-08	30-Jun-09
ROI residential lending	31	129
Commercial lending	12	43
UK lending	17	36
Consumer finance	67	97
Relating to rogue solicitors	12	11
<b>Total provisions</b>	<b>139</b>	<b>316</b>
<b>% of gross loans</b>	<b>0.3%</b>	<b>0.8%</b>

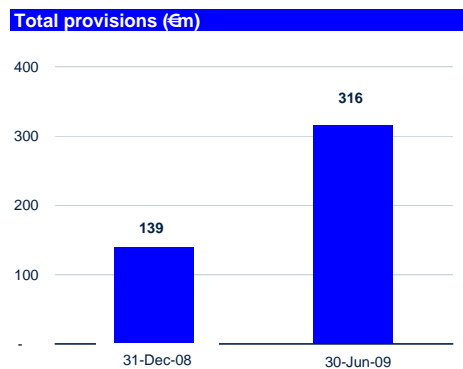

Capital ratios

Bank capital ratios (Basel II)		€m	
	31-Dec-08	30-Jun-09	
Total available capital (Tier 1)	2,059	2,006	
RWA before interim capital requirement	18,173	17,576	
RWA after interim capital requirement	22,353	21,619	
<b>Risk asset ratio (all Core Tier 1)</b>	11.3%	11.4%	
Before application of interim capital req			
After application of interim capital requi	9.2%	9.3%	

Note: Tier 1 capital has no Tier 1 hybrid capital

Solvency cover ratios (Solvency I)		€m	
	31-Dec-08	30-Jun-09	
Minimum capital	410	413	
Regulatory capital	540	532	
Net worth	205	207	
Perpetual debt	24	18	
Other assets available	769	757	
Inadmissible assets	(104)	(100)	
<b>Solvency cover</b>	<b>1.62</b>	<b>1.59</b>	

Source: December 2008 annual report and June 2009 half-year interim report

### Mortgage Lending\*

	30.9.08		30.6.09	
	no.	€m	no.	€m
Approvals	1109	188	522	72
Drawdowns	1043	194	475	76
<b>Total</b>	<b>2152</b>	<b>382</b>	<b>997</b>	<b>148</b>
First time buyers	380	89	275	41

\* ROI residential mortgage lending for the months September 2008 and June 2009

Share price performance (€)

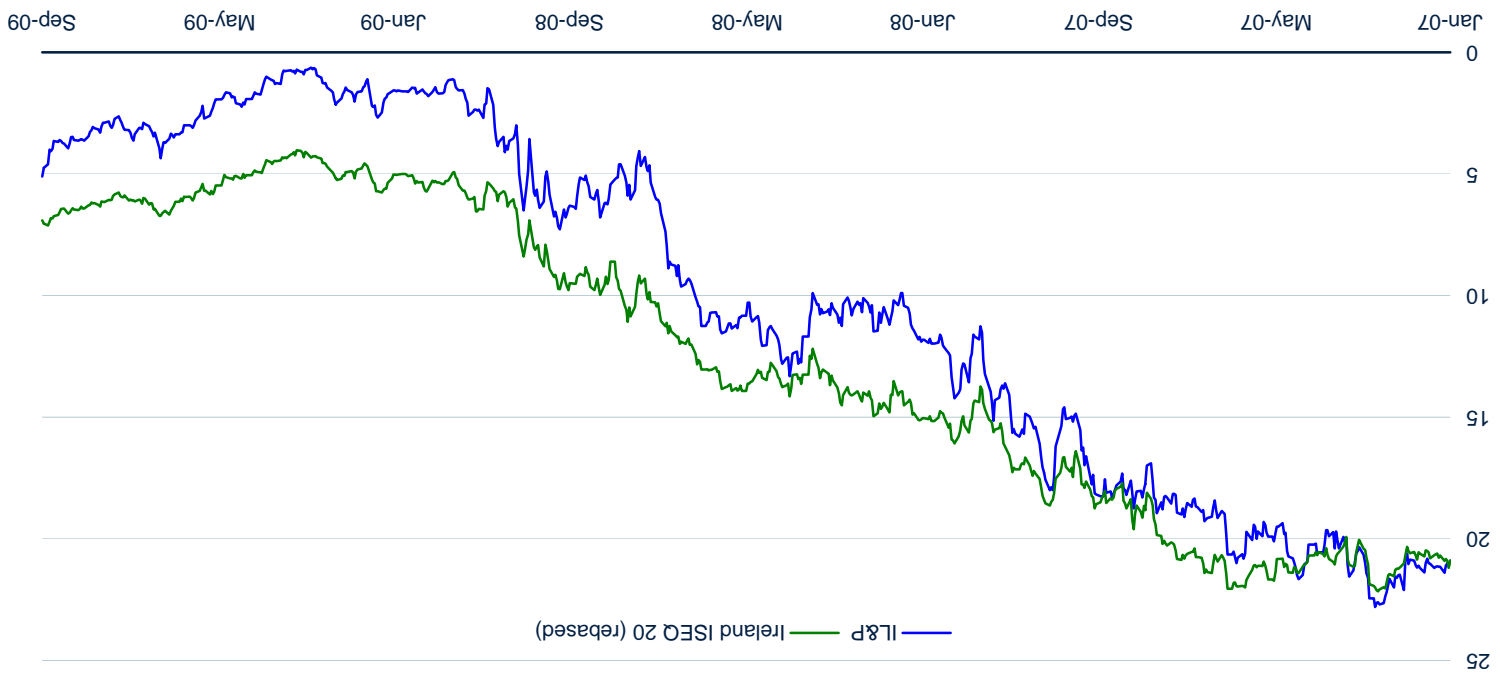

Source: Factset

**CDS spreads - 5 year EUR senior corporate (bps)**



Source: Bloomberg

# ILP Indicative Funding Profile - Interim Report 30 June 2009

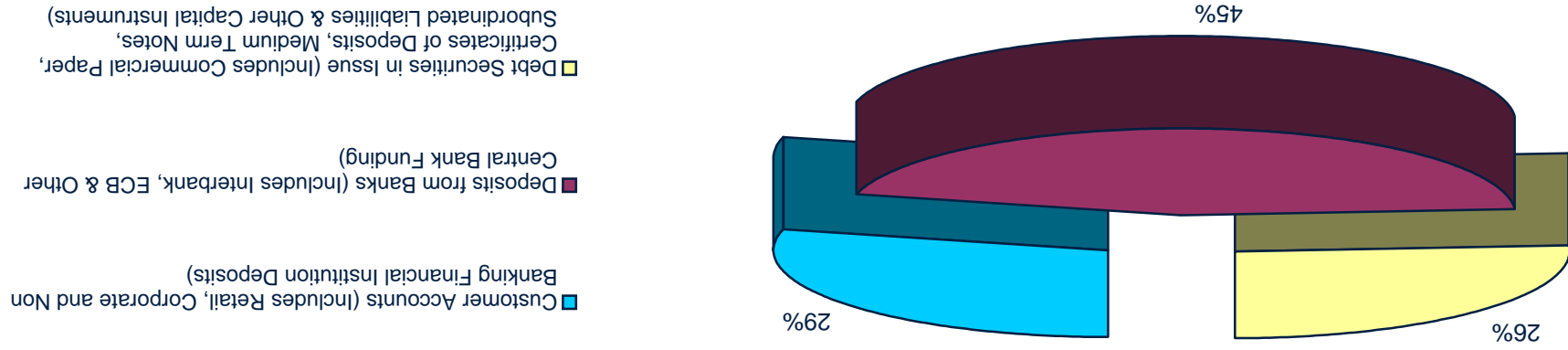



## **INBS INFORMATION PACK**

The information in this document has been confirmed by the institution to which it relates for this publication. It is published for illustrative purposes only and should not be relied upon for any other purpose. The Minister for Finance, the Government of Ireland or their advisers have not independently verified the information and take no responsibility for its accuracy or completeness.

<b>Profit &amp; loss account</b>			
<b>€m, year ended</b>	<b>31-Dec-06</b>	<b>31-Dec-07</b>	<b>31-Dec-08</b>
Net interest income	194.1	297.4	258.3
Non interest income	106.0	186.2	2.1
<b>Total operating income</b>	<b>300.1</b>	<b>483.6</b>	<b>260.4</b>
Administrative expenses	(43.3)	(44.3)	(45.0)
<b>Operating profit before provisions</b>	<b>256.8</b>	<b>439.3</b>	<b>215.4</b>
Provision for impairments on loans to custome	(17.6)	(48.8)	(464.3)
Provision for impairments on available for sale	-	-	(30.9)
<b>Profit before tax</b>	<b>239.2</b>	<b>390.5</b>	<b>(279.8)</b>
Tax	(52.7)	(81.4)	36.9
<b>Profit after tax</b>	<b>186.5</b>	<b>309.1</b>	<b>(242.9)</b>

<b>Balance sheet</b>			
<b>€m</b>	<b>31-Dec-06</b>	<b>31-Dec-07</b>	<b>31-Dec-08</b>
<b>Assets</b>			
Cash and balances at central banks	166	166	159
Loans and receivables to banks	3,556	3,126	3,043
Derivatives	65	204	479
Loans and advances to customers	10,410	12,332	10,474
Financial investments and trading portfolio	106	72	59
Other assets	327	199	215
<b>Total assets</b>	<b>14,629</b>	<b>16,099</b>	<b>14,429</b>
<b>Liabilities</b>			
Deposits by banks	88	175	883
Customer accounts	6,603	7,250	6,785
Derivatives	59	17	28
Debt securities in issue	6,184	6,711	5,200
Subordinated liabilities	366	356	298
Other liabilities	91	80	47
<b>Total liabilities</b>	<b>13,391</b>	<b>14,589</b>	<b>13,240</b>
General reserve	1,056	1,364	1,119
Other reserves	181	146	71
<b>Total liabilities and shareholders' equity</b>	<b>14,629</b>	<b>16,099</b>	<b>14,429</b>
Number of employees	408	400	385

## Loan book by sector

### Loan book development (net)

€m	31-Dec-03	31-Dec-04	31-Dec-05	31-Dec-06	31-Dec-07	31-Dec-08
Real estate	1,256	1,904	3,295	5,363	5,786	4,824
Construction	252	288	240	362	1,611	1,592
Other commercial	940	1,264	1,745	2,086	2,388	1,768
Residential	1,800	2,097	2,292	2,599	2,547	2,291
<b>Total loan book (net)</b>	<b>4,248</b>	<b>5,553</b>	<b>7,572</b>	<b>10,410</b>	<b>12,332</b>	<b>10,474</b>

### Split of net loan book by sector (Dec 2008)

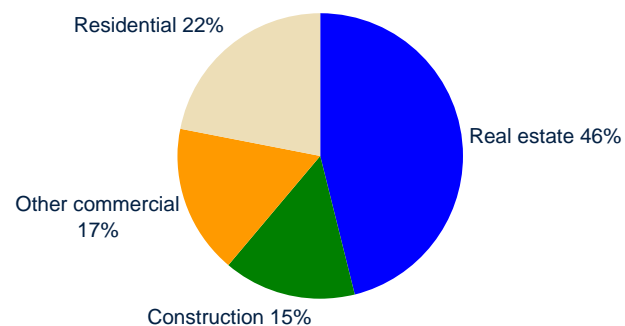

### Evolution of total net loan book (€m)

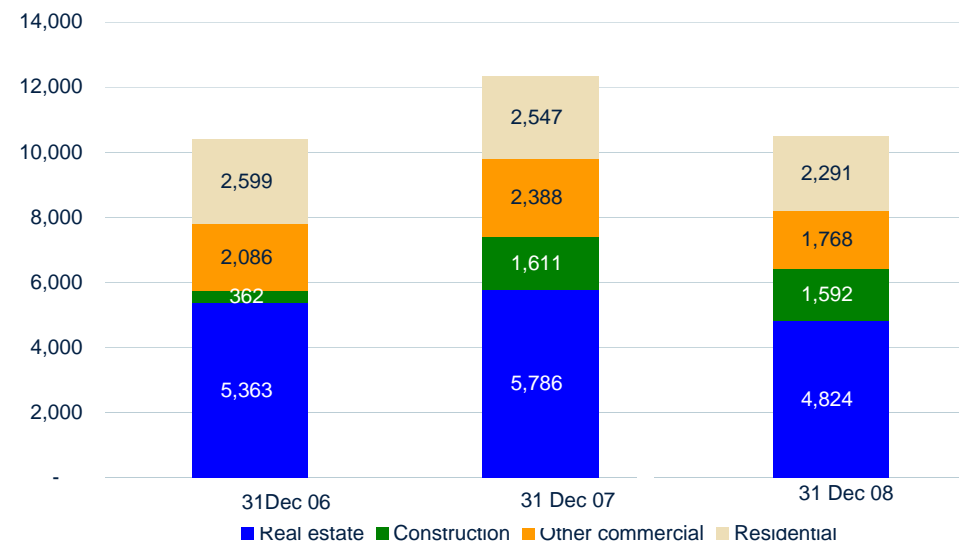

Loan Book by geography

**€m, 31 Dec 2008**

Geographic breakdown of loan book (net)		UK	Europe	Total
Residential loans	2,242	19	30	2,291
Commercial property loans	2,727	4,387	1,069	8,183
<b>Total</b>	<b>4,969</b>	<b>4,406</b>	<b>1,099</b>	<b>10,474</b>
<b>% of total</b>	<b>47.4%</b>	<b>42.1%</b>	<b>10.5%</b>	<b>100.0%</b>

**Split of loan book by region (Dec 2008)**

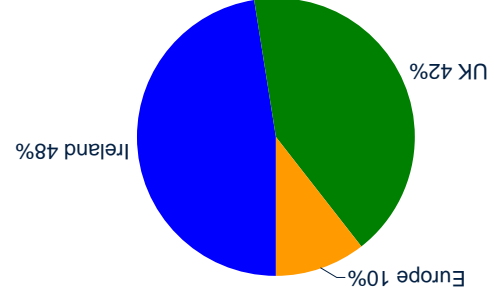

Land & Development

Geographic breakdown of Land & Development Loan Book €m, 30 June 2009				
	Ireland	UK	Europe	Total
Total	2,402	2,696	475	5,573
% of total	43.1%	48.4%	8.5%	100.0%

Geographic breakdown of Land & Development Loan Book €m, 30 September 2008				
	Ireland	UK	Europe	Total
Total	2,282	2,694	440	5,416
% of total	42.1%	49.7%	8.1%	100.0%

Geographic breakdown of Land & Development Loan Book 30th June

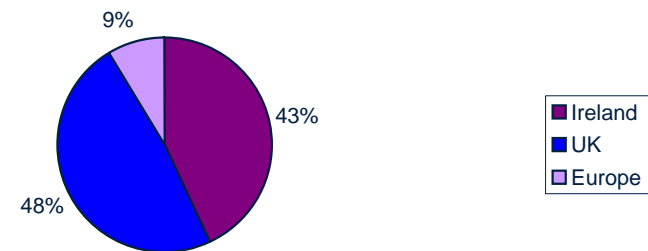

Loan book quality

Critised / unsatisfied loans summary (net)		
	31-Dec-07	31-Dec-08
€m		
Satisfactory risk	11,436	7,493
Watch risk	784	1,822
Impaired loans	111	1,159
<b>Total loans and receivables to custor</b>	<b>12,332</b>	<b>10,474</b>
<b>Impaired loans as % of gross loans</b>	<b>0.9%</b>	<b>11.1%</b>

Provisions for impairments on loans and receivables to customers		
	31-Dec-07	31-Dec-08
€m		
Commercial - Ireland	26.8	349.7
Commercial - UK	64.0	166.1
Residential	8.3	29.4
<b>Total provisions</b>	<b>99.1</b>	<b>545.2</b>
<b>Gross loans</b>	<b>12,431</b>	<b>11,019</b>
<b>% of gross loan book</b>	<b>0.8%</b>	<b>4.9%</b>

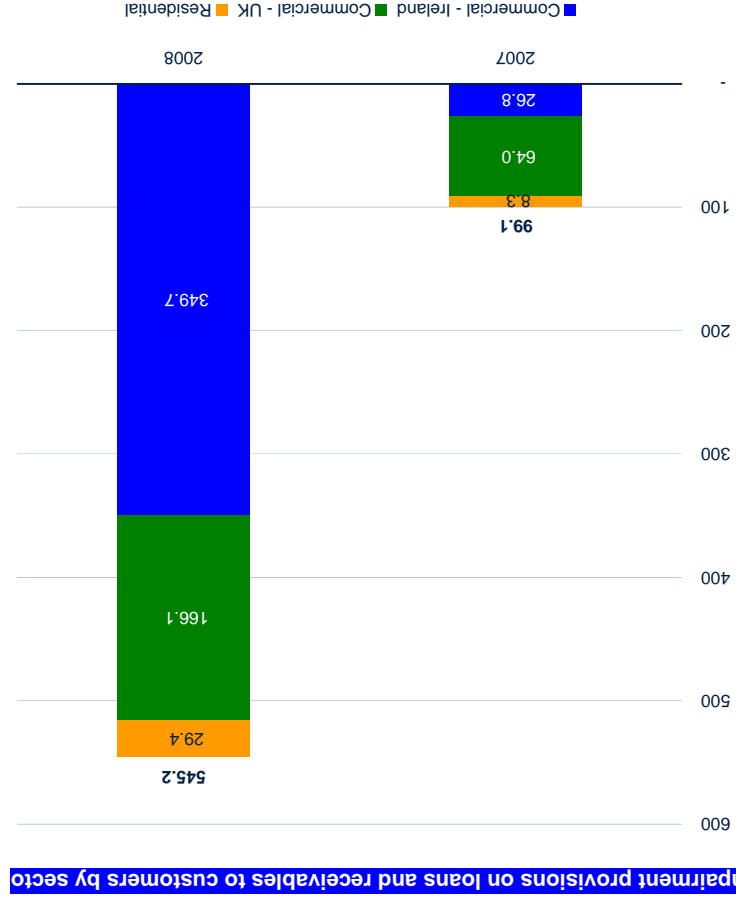

## Deposits breakdown

Geographic breakdown of customer deposits €m			
	30-Jun-08	31-Dec-08	30-Jun-09
Ireland	5,389	4,763	4,246
NI	-	1	32
Rest of world	2,230	2,021	1,608
<b>Total</b>	<b>7,619</b>	<b>6,785</b>	<b>5,886</b>

Number of customer depts 000s			
	30-Jun-08	31-Dec-08	30-Jun-09
Ireland	194	197	185
Rest of world	8	9	7
<b>Total</b>	<b>202</b>	<b>206</b>	<b>192</b>

### Notes:

The geographic analysis of customer deposits is based on the location of the office recording the transactions.

**Capital ratios**

Capital ratios €m	31/12/2007 <sup>2</sup>	31/12/2008 <sup>1</sup>
Tier 1 capital	1,057	1,103
Total capital	1,575	1,545
Risk weighted assets <sup>3</sup>	12,291	14,825
<b>Tier 1 ratio</b>	<b>8.6%</b>	<b>7.4%</b>
<b>Total capital ratio</b>	<b>12.9%</b>	<b>10.4%</b>

Notes

1 Under Basel II

2 Under Basel I

3 RWA calculated based on stated Tier 1 capital and Tier 1 ratio figures

Source: December 2008 annual report

### Subordinated debt buy back

#### Comment

The Society realised a profit in August 2009 from the buyback of senior notes maturing in 2012, the repurchase of lower tier 2 subordinated notes and from the closure of interest rate swaps with the repurchased notes. The repurchase was financed through the issuance of new notes.

#### Debt Buyback

	€m
Subordinated debt before buy back (notional amount)	293
Subordinated debt after buy back (notional amount)	172
Profit made on subordinated debt buyback	121

#### Bank capital ratios (Basel II) at 31 December 2008 €m

	Before buy back	*After buyback
Tier 1 capital	1,103	1,394
Total capital	1,545	1,716
Risk weighted assets	14,825	14,825
<b>Tier 1 ratio</b>	<b>7.4%</b>	<b>9.4%</b>
<b>Total capital ratio</b>	<b>10.4%</b>	<b>11.6%</b>

#### \*After buy-back:

The capital position at 31 December 2008 has been adjusted to include the profit from the debt buy-back and the reduction in the subordinated debt. This is an indicative position only.

Mortgage Lending (Comparison between September 2008 and June 2009)

	30.09.08	no.	€m	30.06.09	no.	€m
Approvals	21	1.43	9	0.34		
First time buyers	0	0	0	0.00		
<b>Drawdowns</b>	59	2.13	26	0.81		
First time buyers	3	0.09	0	0.00		

# INBS Indicative Funding Profile - Annual Report 31 December 2008

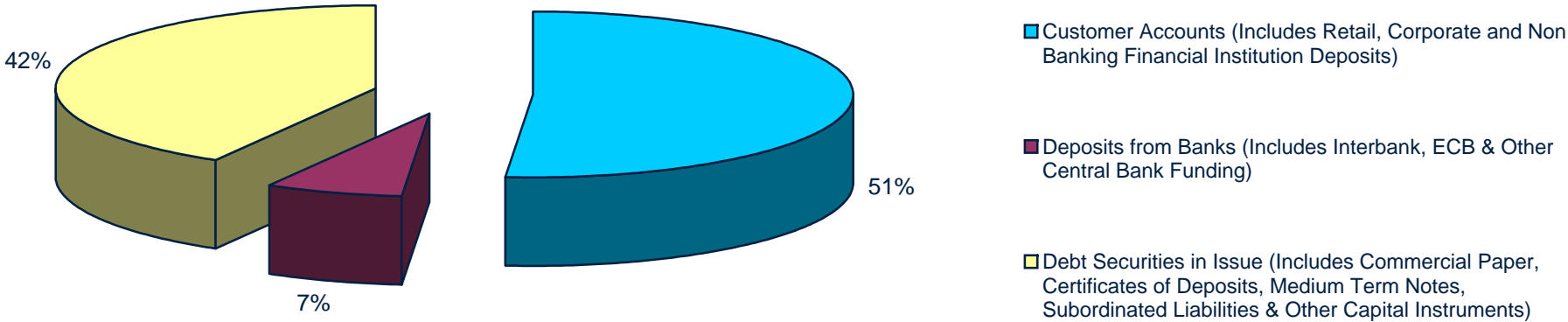

**EBS INFORMATION PACK**

<b>Profit &amp; loss account</b>				
<b>€m, year ended</b>	<b>31-Dec-06</b>	<b>31-Dec-07</b>	<b>31-Dec-08</b>	<b>30-Jun-09</b>
Net interest income	150.1	173.6	155.1	71.8
Non interest income	19.7	20.2	17.2	10.8
<b>Total operating income</b>	<b>169.8</b>	<b>193.8</b>	<b>172.3</b>	<b>82.6</b>
<b>Total operating expenses</b>	<b>(99.3)</b>	<b>(108.1)</b>	<b>(100.5)</b>	<b>(47.5)</b>
<b>Operating profit before provision</b>	<b>70.5</b>	<b>85.7</b>	<b>71.8</b>	<b>35.1</b>
Provision for impairments	(4.6)	(19.1)	(110.0)	(43.9)
<b>Profit before tax</b>	<b>65.9</b>	<b>66.6</b>	<b>(38.2)</b>	<b>(8.8)</b>
Tax	(8.2)	(10.7)	0.4	4.0
<b>Profit after tax</b>	<b>57.7</b>	<b>55.9</b>	<b>(37.8)</b>	<b>(4.8)</b>

<b>Balance sheet</b>		<b>€m</b>	
	<b>31-Dec-06</b>	<b>31-Dec-07</b>	<b>31-Dec-08</b>
	<b>30-Jun-09</b>		
<b>Assets</b>			
Cash and balances at central banks	310	281	143
Loans and receivables to banks	1,012	276	1,288
Derivatives	44	58	51
Loans and advances to customers	14,634	15,882	16,901
Financial assets	2,993	2,675	2,741
Goodwill and intangibles	17	21	27
Other assets	295	283	223
<b>Total assets</b>	<b>19,306</b>	<b>19,476</b>	<b>21,374</b>
<b>Liabilities</b>			
Deposits by banks	1,108	2,657	6,104
Customer accounts	10,071	9,544	10,126
Derivatives	73	153	202
Debt securities in issue	6,821	5,677	3,683
Subordinated debt	266	261	213
Other liabilities	307	355	379
<b>Total liabilities</b>	<b>18,646</b>	<b>18,646</b>	<b>20,706</b>
Reserves	537	584	423
Minority interests	123	245	245
<b>Total liabilities and shareholders' equity</b>	<b>19,306</b>	<b>19,476</b>	<b>21,374</b>
Number of employees	634	655	692
			666
			<b>22,167</b>

Loan book development €m	31-Dec-03	31-Dec-04	31-Dec-05	31-Dec-06	31-Dec-07	31-Dec-08	30-Jun-09
Home loans	7,039	8,119	9,549	11,134	12,032	13,107	13,339
Residential Investment	782	1,105	1,603	2,036	2,166	2,147	2,127
Commercial property	661	894	965	1,225	1,287	1,249	1,203
Land & Development	23	76	108	257	434	512	524
<b>Gross total</b>	<b>8,505</b>	<b>10,193</b>	<b>12,225</b>	<b>14,652</b>	<b>15,919</b>	<b>17,014</b>	<b>17,193</b>
Less impairment provisions	(23)	(24)	(14)	(18)	(37)	(114)	(158)
<b>Total</b>	<b>8,482</b>	<b>10,170</b>	<b>12,211</b>	<b>14,634</b>	<b>15,882</b>	<b>16,901</b>	<b>17,036</b>

### Split of gross loan book (30 June 2009)

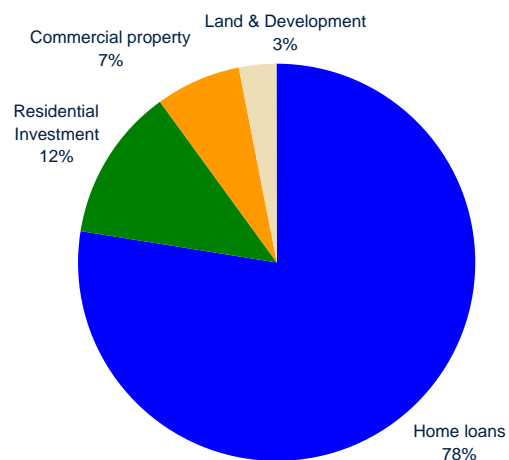

### Evolution of gross loan book €m

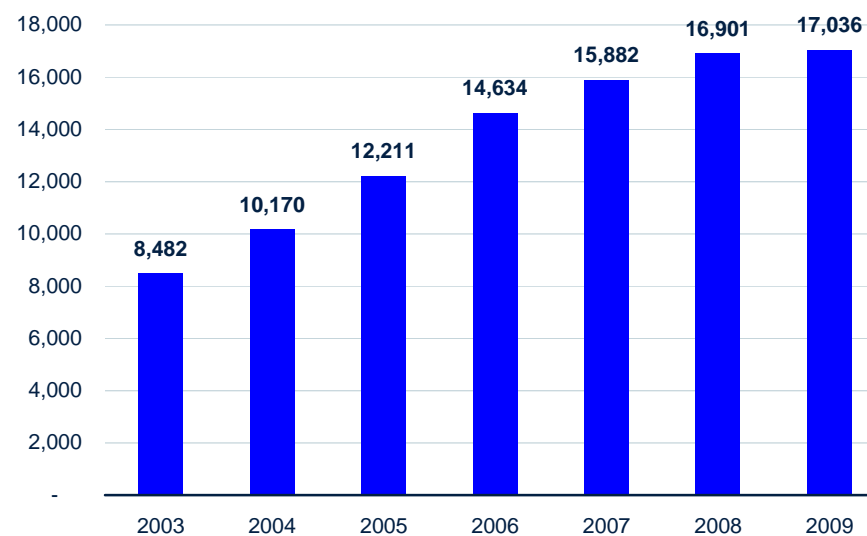

Loan Book by geography

30 June 2009

Geographic breakdown of loan book				
€m				
	UK	Rest of the World	Total	% of total
Property and Construction	481	-	525	
Mortgages	15,402	-	15,458	
Consumer lending	-	-	-	
Corporate / SME*	1,053	44	1,210	
<b>Gross total</b>	<b>16,936</b>	<b>44</b>	<b>17,193</b>	
Less unearned income and provisi	(158)	-	(158)	
<b>Total</b>	<b>16,778</b>	<b>214</b>	<b>17,035</b>	

\* Dry commercial investment property only

30 September 2008

Geographic breakdown of loan book				
€m				
	UK	Rest of the World	Total	% of total
Property and Construction	471	-	517	
Mortgages	15,008	-	15,070	
Consumer lending	-	-	-	
Corporate / SME*	1,097	61	1,283	
<b>Gross total</b>	<b>16,577</b>	<b>61</b>	<b>16,871</b>	
Less unearned income and provisi	(45)	-	(45)	
<b>Total</b>	<b>16,532</b>	<b>232</b>	<b>16,826</b>	

### Geographic Breakdown of Land and Development loan book

	30.9.08	30.6.09
	€m	€m
Ireland	470	480
UK	46	45
US	0	0
Other	0	0
<b>Total</b>	<b>516</b>	<b>524</b>

### Geographic Breakdown of L&D Loan Book 30th June 2009

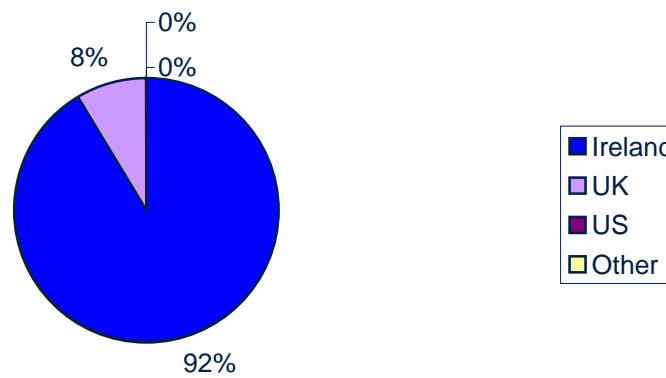

Loan book quality

Criticised / unsatisfied loans summary

	€m		
	31-Dec-07	31-Dec-08	30-Jun-09
Watch loans	120	437	603
Vulnerable loans*	201	431	697
Impaired loans**	37	321	407
<b>Total criticised loans</b>	<b>358</b>	<b>1,189</b>	<b>1,707</b>
% of total gross loans	2.3%	7.0%	10.7%

\* Non-performing loans without individual provisions  
 \*\* Individually significant provisions

	€m		
	31-Dec-07	31-Dec-08	30-Jun-09
<b>Individual provision for loan impairments</b>	<b>3</b>	<b>20</b>	<b>70</b>
At 1 January	17	66	26
Charge for impairment losses: Commercial	17	66	26
Charge for impairment losses: Retail	-	2	1
Loans and advances written off	(0)	(18)	-
<b>At 31 December / 30 Jun</b>	<b>20</b>	<b>70</b>	<b>97</b>
<b>Collective provision for loan impairments</b>	<b>15</b>	<b>17</b>	<b>44</b>
At 1 January	2	19	7
Charge for impairment losses: Commercial	2	19	7
Charge for impairment losses: Retail	1	10	10
Loans and advances written off	(0)	(3)	-
<b>At 31 December / 30 Jun</b>	<b>17</b>	<b>44</b>	<b>61</b>
<b>Total provision for loan impairments at period end</b>	<b>37</b>	<b>114</b>	<b>158</b>
% of customer loan book	0.23%	0.67%	0.93%

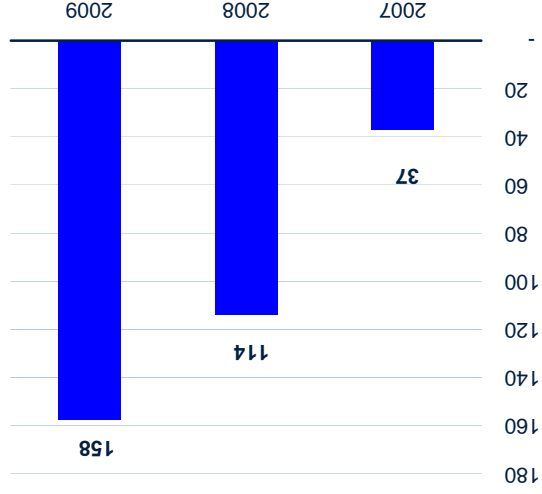

Total provision for loan impairments (€m)

## Capital ratios

<b>Capital ratios</b>			
<b>€m</b>	<b>31-Dec-07</b>	<b>31-Dec-08</b>	<b>30-Jun-09</b>
<b>Tier 1 capital</b>	<b>811</b>	<b>774</b>	<b>769</b>
<b>Total regulatory capital</b>	<b>1,077</b>	<b>1,039</b>	<b>1,058</b>
Risk weighted assets	9,049	9,781	9,984
Tier 1 ratio	9.0%	7.9%	7.7%
Total capital ratio	11.9%	10.6%	10.6%

Source: December 2008 annual report, June 2009 half-year interim report

Capital ratios

Capital ratios	31-Dec-07	31-Dec-08
Tier 1 capital	811	774
Total regulatory capital	1,077	1,039
Risk weighted assets	9,049	9,781
Tier 1 ratio	9.0%	7.9%
Total capital ratio	11.9%	10.6%

Source: December 2008 annual report, June 2009 half-year interim report

## Mortgage Lending

	9 months ending 30/09/2008		9 months ending 30/06/2009	
	no.	€m	no.	€m
Approvals	4,834	1,184	3,297	705
Drawdowns*	5,011	1,199	2,835	638
Total				
First time buyers - Approvals	2,509	587	2,015	420
First time buyers - Drawdowns*	2,568	614	1,668	365

\* The number of advanced loans is not entirely connected to the number of approvals in the preceding 9 months. There may be approved loans outside this time period which were drawn down in the 9 months being analysed.

# EBS Indicative Funding Profile - Interim Results June 30 2009

